

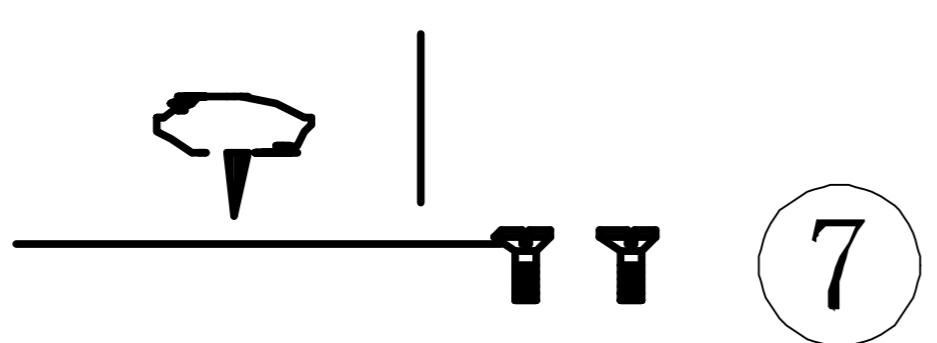
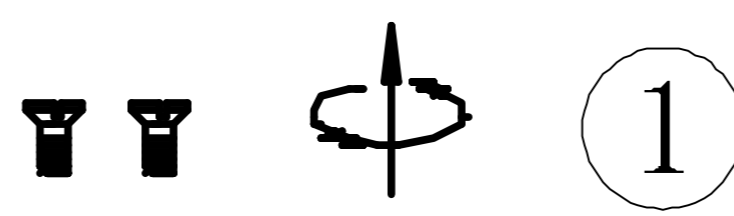
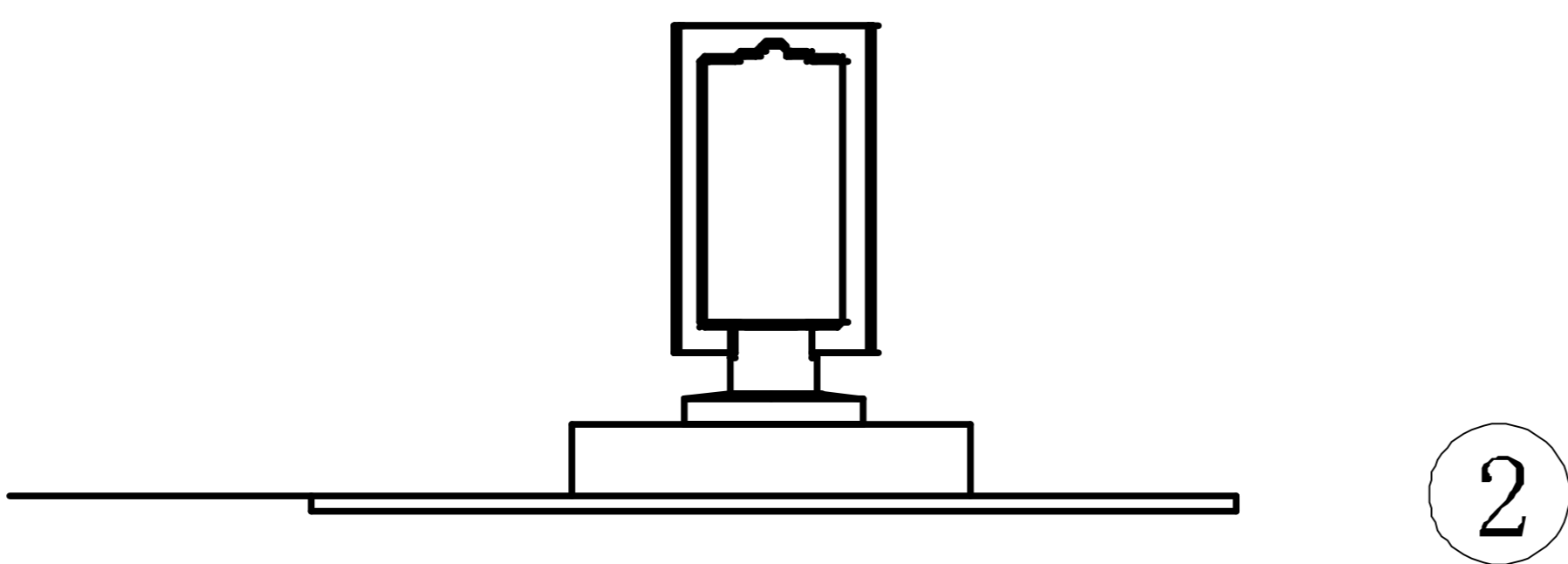
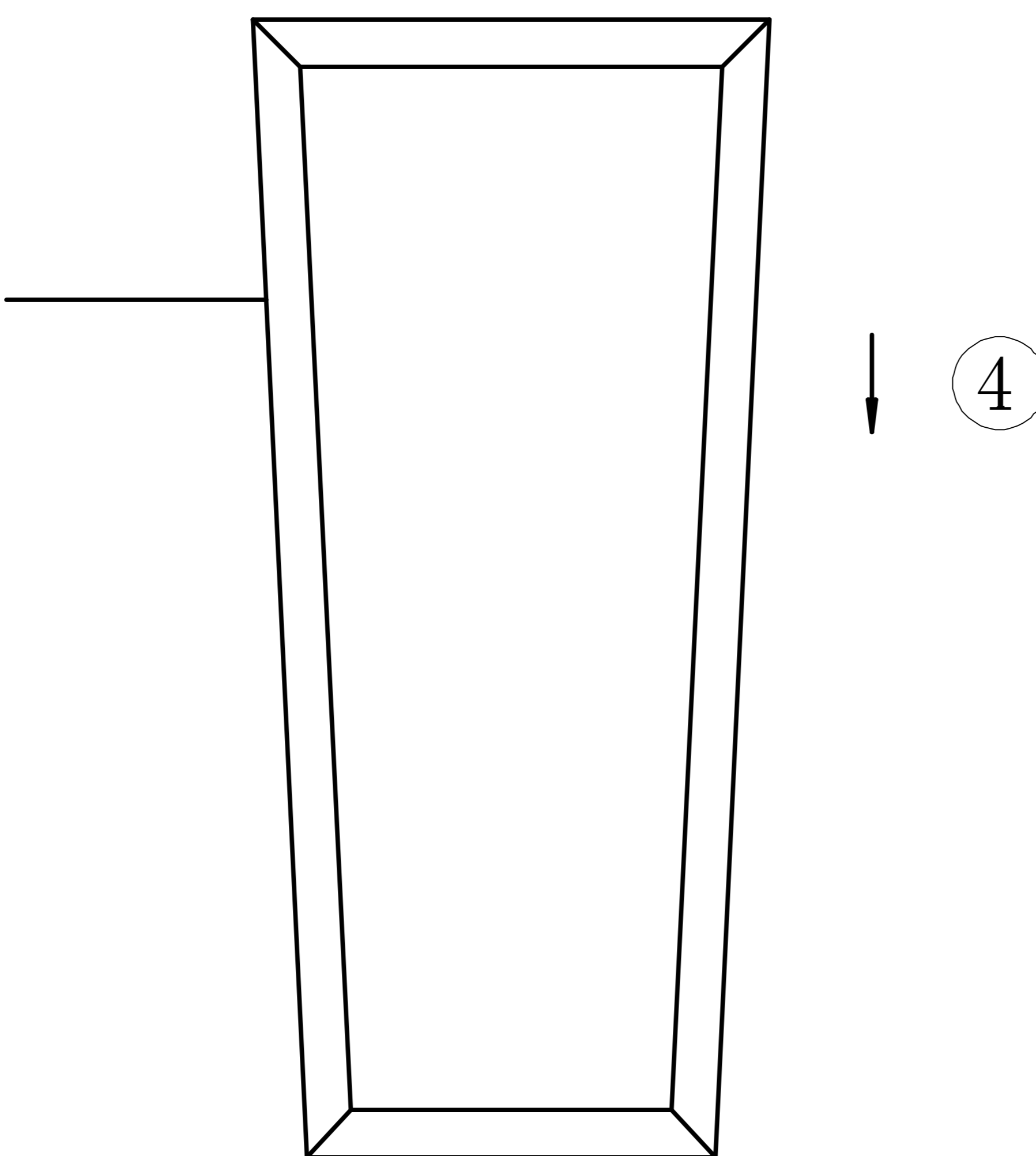

ITEM: 9952-1PLT-23

DESIGN COPYRIGHT – 11/18/2025
ALL RIGHTS RESERVED AND MAY NOT
BE DUPLICATED WITHOUT OUR
WRITTEN PERMISSION

MACHINE SCREWS  

UPPER COVER 

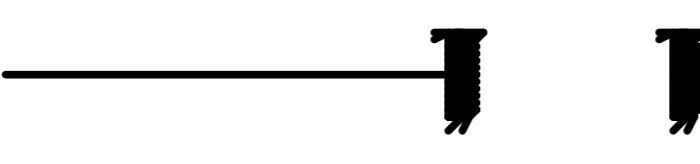
GLASS 

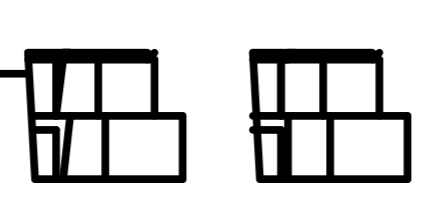
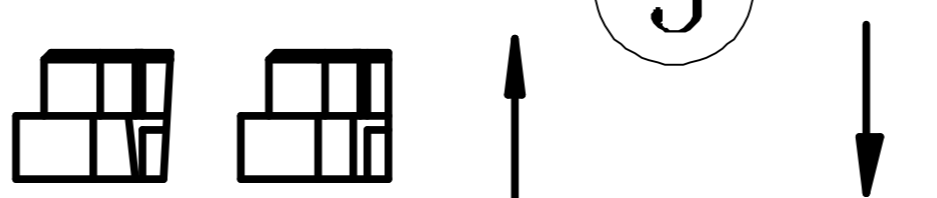
SELF-TAPPING SCREWS  
CLIP  

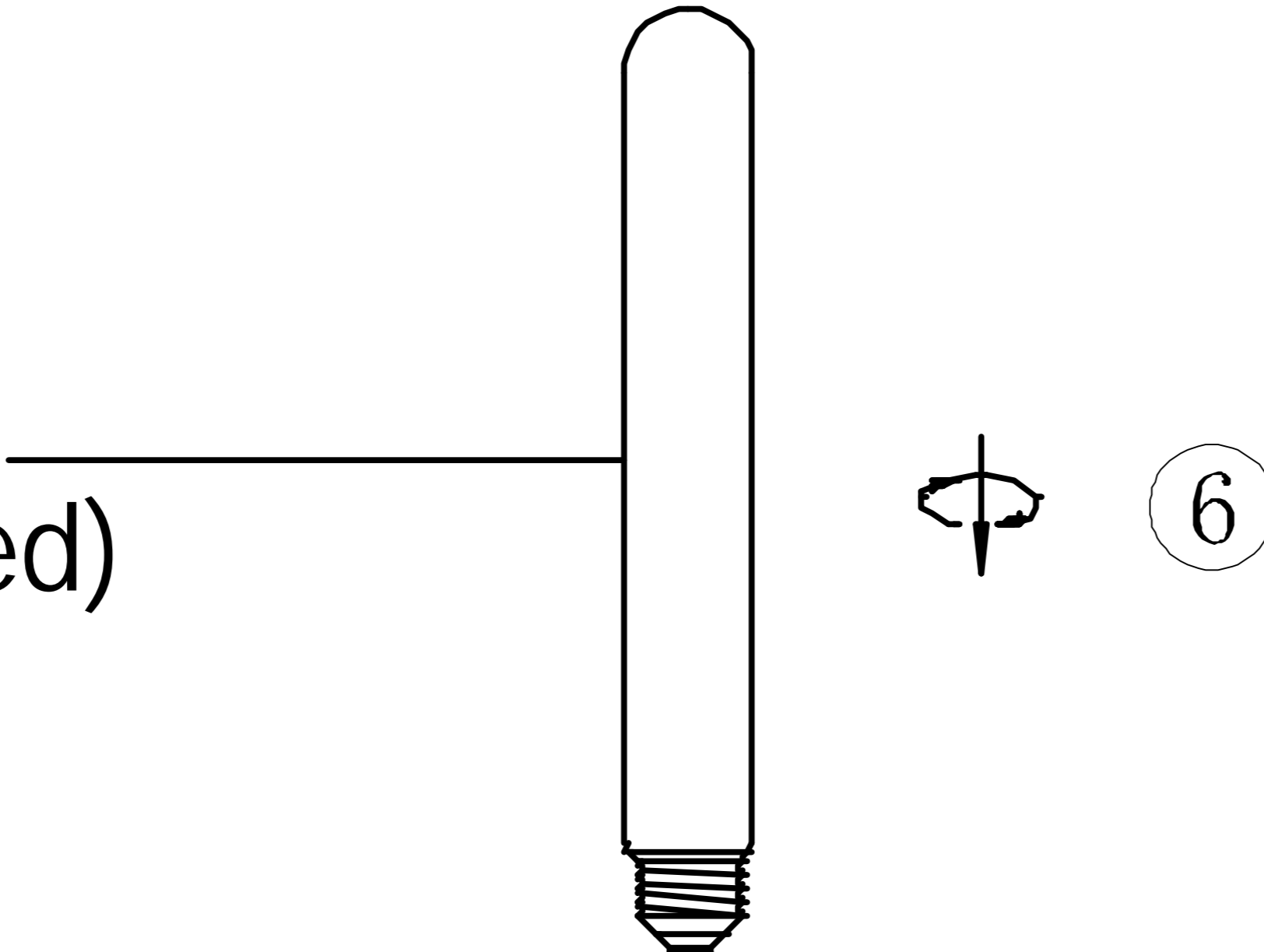
BULB
(Not provided) 

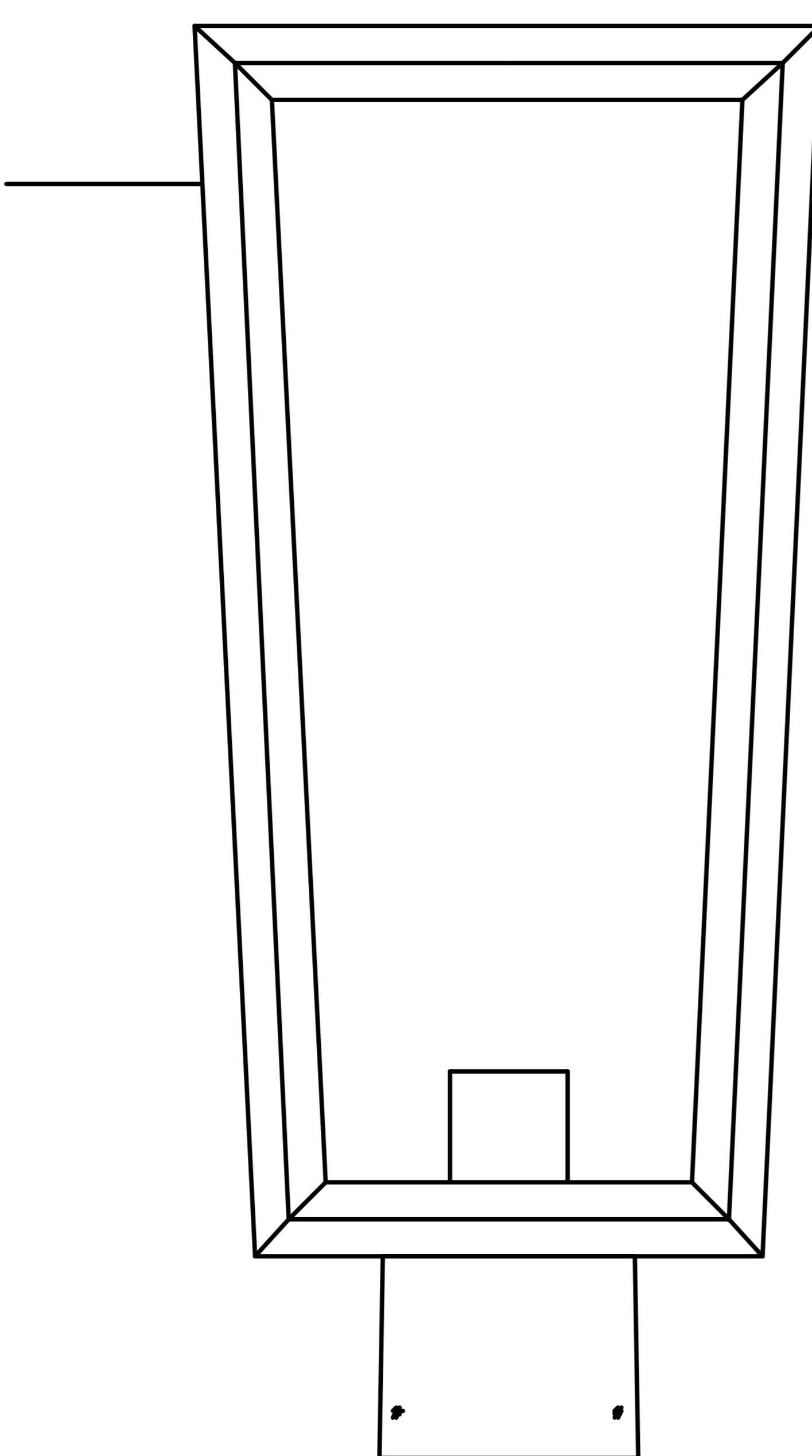
FRAME 

step1: Remove the machine screws

step2: Take out the socket assembly set from the frame

step3: take out the clips by loosening the self-tapping screws.

step4: Install the glass panels into the frame

step5: Tighten 4 clips by self-tapping screws

step6: Install the bulb

step7: Assemble the socket assembly set and the frame with machine screws

STANDARD MOUNTING PLATE INSTALLATION INSTRUCTIONS

FOR YOUR SAFETY WARNING

Risk of Fire, Consult a qualified electrician to ensure correct branch circuit conductor.

Turn off the main power at the circuit breaker before installing the fixture in order to prevent possible shock.

General

All electrical connections must be in accordance with local and National Electrical Code (N.E.C.) standards. If you are unfamiliar with proper electrical wiring connections obtain the services of a qualified electrician. Remove the fixture and the mounting package from the box and make sure that no parts are missing by referencing the illustration.

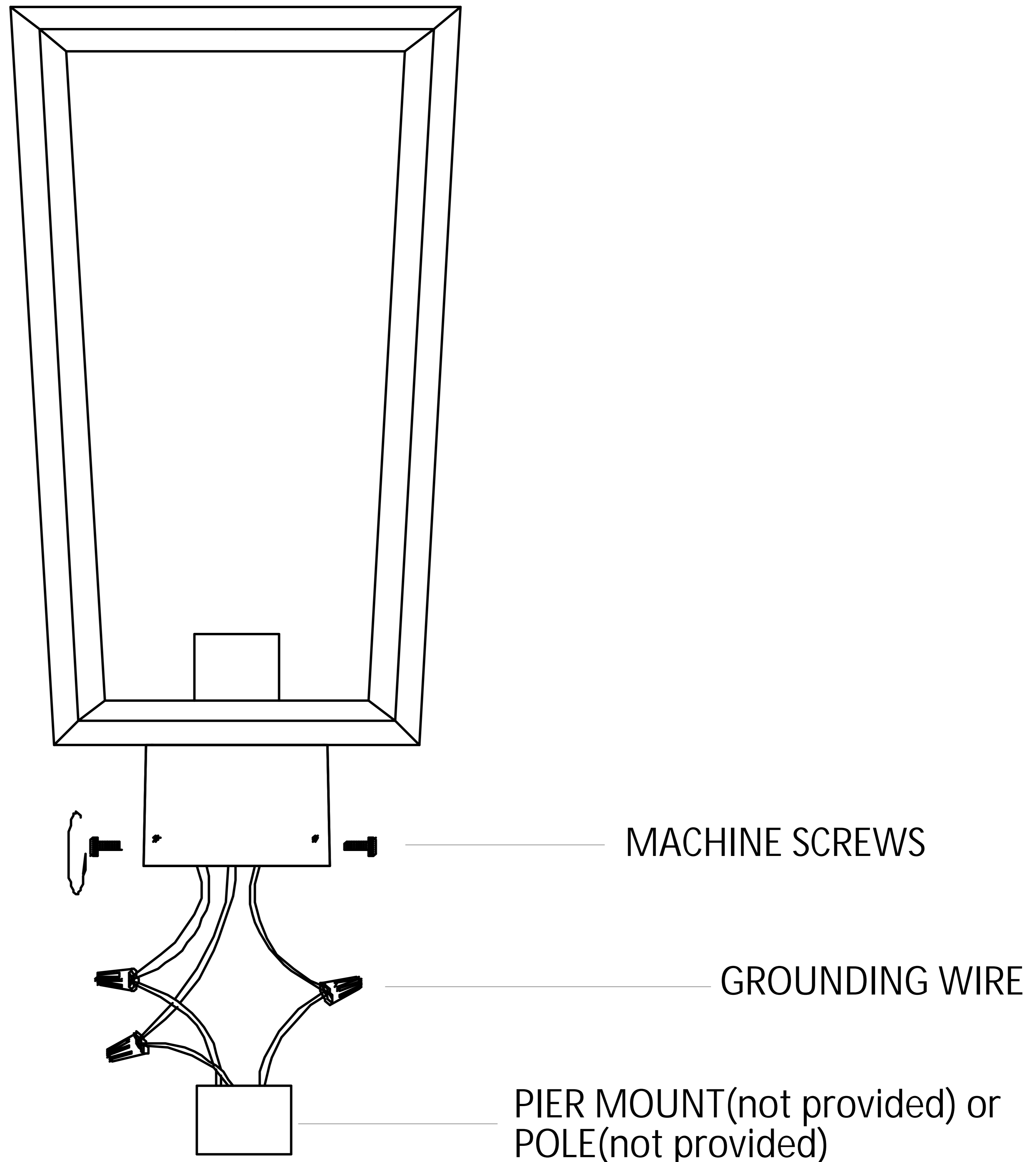

CAUTION: DISCONNECT POWER DURING INSTALLATION

- 1.) If you are replacing an existing fixture, disconnect and remove the old fixture. Expose the supply wiring from the outlet box.
- 2.) Remove the machine screws on the lamp cup.
- 3.) Spread the electrical wires so that the black wires are on one side of the outlet box and the white wires are on the other side.
- 4.) Grounding instructions:
 - A.) On fixtures where mounting plate is provided with a green ground screw and two raised dimples, Wrap ground wire from outlet box around green ground screw and tighten.
 - B.) On fixtures where mounting plate is provided with a green ground wire attached. Connect mounting plate ground wire to ground wire from outlet box with wire connector. If fixture is provided with ground wire. Connect fixture ground wire to ground wire from outlet box with wire connector. After following the above steps. Never connect ground wire to black or white power supply wires.
- 5.) To make electrical connections: Connect the white wire(s) from the fixture to the white wire of this outlet box. Connect the black wire(s) from the fixture to the black wire of the outlet box. NOTE: Black wire from outlet box may be red, round & smooth and/or have copper conductor. White wire from outlet box may be square & ridged and/or have a silver conductor. After wires are connected, tuck them carefully inside post base.
- 6.) Place fixture onto pier mount or pole. Tight the machine screws.