

## ASSEMBLY INSTRUCTION MODEL #TRL-2801-LG

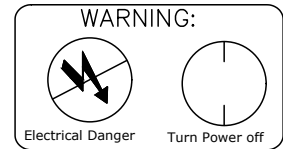

All electrical components must be installed by a licensed electrician in accordance with the National Electric Code and the appropriate local electrical codes.

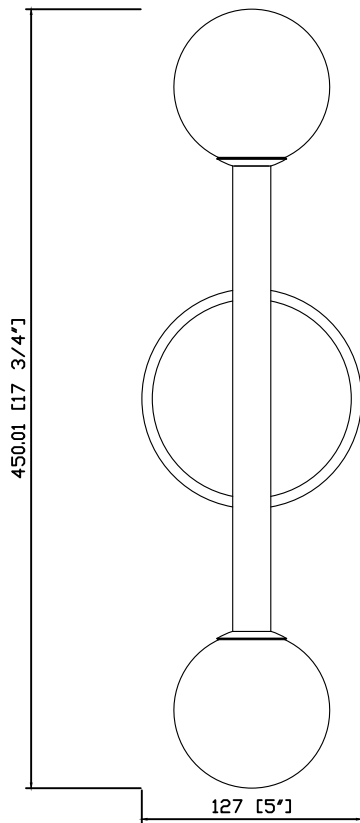
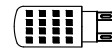

You will need 2 - 3.5 Watts G9 LED bulb included

**THIS FIXTURE IS Damp RATED**

### How to Install

1. Remove the mounting plate from the back plate and install it onto the outlet box using the two outlet box screws.
2. Place the back plate over the mounting plate and secure with the screws.
3. Install the bulb onto the socket.
4. Screw the glass shade onto the socket.

This fixture can be mounted both vertically and horizontally

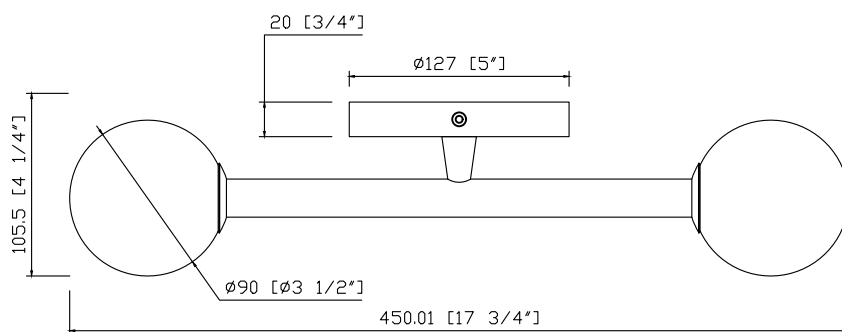

**WARNING:** This product can expose you to Lead, which is known to the State of California to cause cancer and/or birth defects or reproductive harm. For more information go to [www.P65Warnings.ca.gov](http://www.P65Warnings.ca.gov)



PART NUMBER MODEL #TRL-2801-LG

## Part Number

### Part Numbers

- A. (1)-Mounting hardware
- B. (2)-Screws
- C. (1)-Backplate (XAR2801LGBKP5IN)
- D. (2)-G9 LED bulb
- E. (2)-Glass (XAR2801GLA3.5IN)

