

CRYSTORAMA LIGHTING

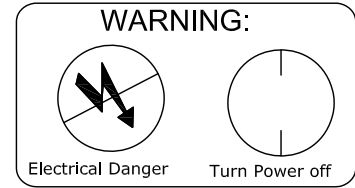

ASSEMBLY INSTRUCTION MODEL #MOR-8801-AG

For Hard-wired

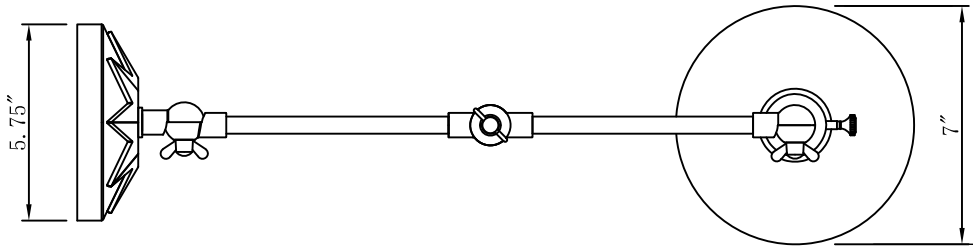

All electrical components must be installed by a licensed electrician in accordance with the National Electric Code and the appropriate local electrical codes.



You will need 1- Medium Base Bulb
40 Watts Recommended 60 Watts Max.
USE LED BULBS FOR EXTENDED USE

THIS FIXTURE IS DRY RATED

For Plug-in

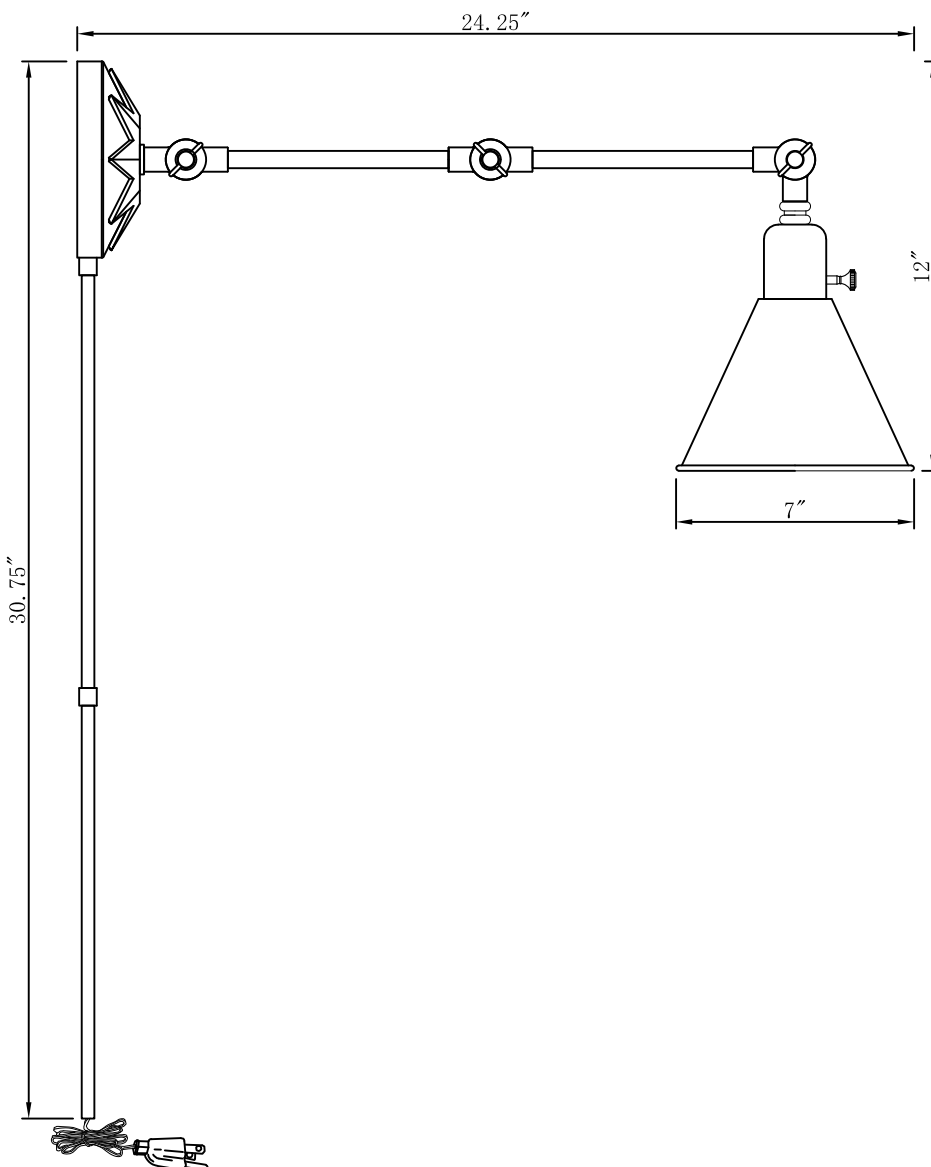

Please place the fixture frame on a soft cloth covered table before the installation.

This is a convertible piece. Installation steps for both Hard-wired and Plug-in options are below.

For Hard-wired installation, please proceed as follows:

1. Remove the plug wires from the fixture wires.
2. Remove the Nut (K) from the bottom of Back plate (B) and cover the hole with plug (J).
3. Attach the mounting plate onto the Junction box using two mounting screws.
4. Attach the Back plate onto the mounting plate. Secure with side screws.
5. Attach the Shade (G) onto the Socket (E) and secure it using the Socket Ring (H).

For Plug-in installation, please proceed as follows:

1. Connect Rod (I) to the bottom of Back plate (B).
2. Determine the desired location you'd like to put this fixture on the wall, and mark two points on it with same distance as between the holes on the mounting plate.
3. Drill the holes at the marked points and insert the anchors into the holes. Attach the mounting plate onto the wall by anchor screws.
4. Attach the Back plate (B) onto mounting plate.
5. Attach the Shade (G) onto Socket (E) and secure it using the Socket Ring (H).

WARNING: This product can expose you to Lead which is known to the state of California to cause cancer and/or birth defects or reproductive harm. For more information go to www.P65Warnings.ca.gov

CRYSTORAMA LIGHTING



ASSEMBLY INSTRUCTION MODEL #MOR-8801-AG

Part Number

Part Numbers

- A. (1)-Mounting Hardware
- B. (1)-Back Plate W5.75" x H1.6" (XFW8800AGBK5.75IN)
- C. (3)-Locking Device (XFW8800AGLOCKD)
- D. (2)-Swing Arm
- E. (1)-Socket
- F. (1)-Switch
- G. (1)-Metal Shade W7"xH5" (XFW8800AGSHA5IN)
- H. (1)-Socket Ring
- I. (2)-Rod W0.375"xH12" (XFW8800AGROD12IN)
- J. (1)-Plug
- K. (2)-Nut
- L. (3)-Screw

