

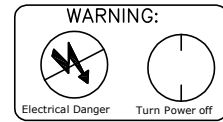

ASSEMBLY INSTRUCTION MODEL #DUM-9802-GE

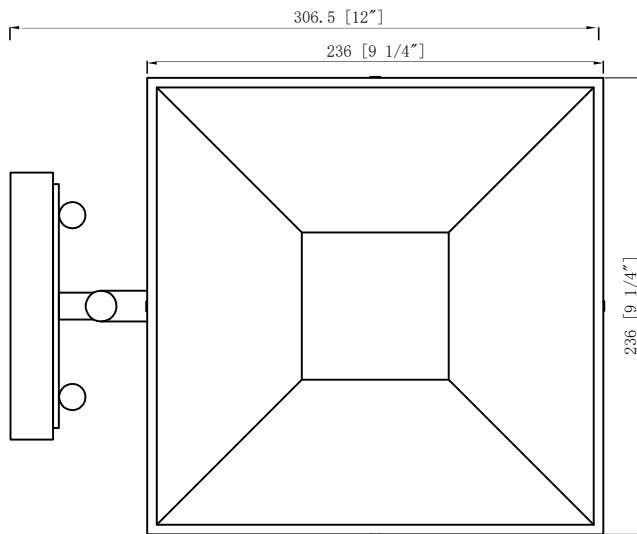

All electrical components must be installed by a licensed electrician in accordance with the National Electric Code and the appropriate local electrical codes.



You will need 3 - Cand. Bulb
40 Watts Recommended 60 Watts Max

USE LED BULBS FOR EXTENDED USE

THIS FIXTURE IS WET RATED

How to Install

1. Remove the top cage by loosening the cap nuts and install the bulb into the socket.
2. Insert the glass into the frame and secure with the clip.
3. Place the top cage onto the metal frame and secure with the cap nut.
4. Attach the mounting plate to the outlet box using two outlet box screws.
5. Install the back plate onto the mounting plate. Secure it with 4 ball nuts.

Sketch Map

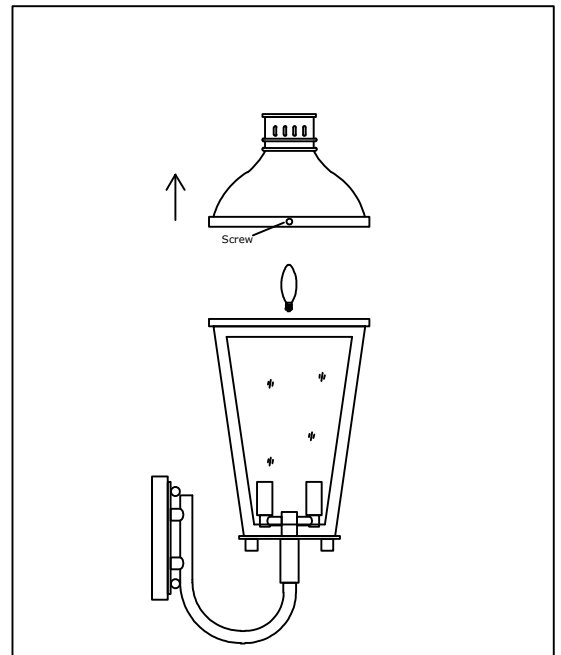

WARNING: This product can expose you to Lead, which is known to the State of California to cause cancer and/or birth defects or reproductive harm. For more information go to www.P65Warnings.ca.gov

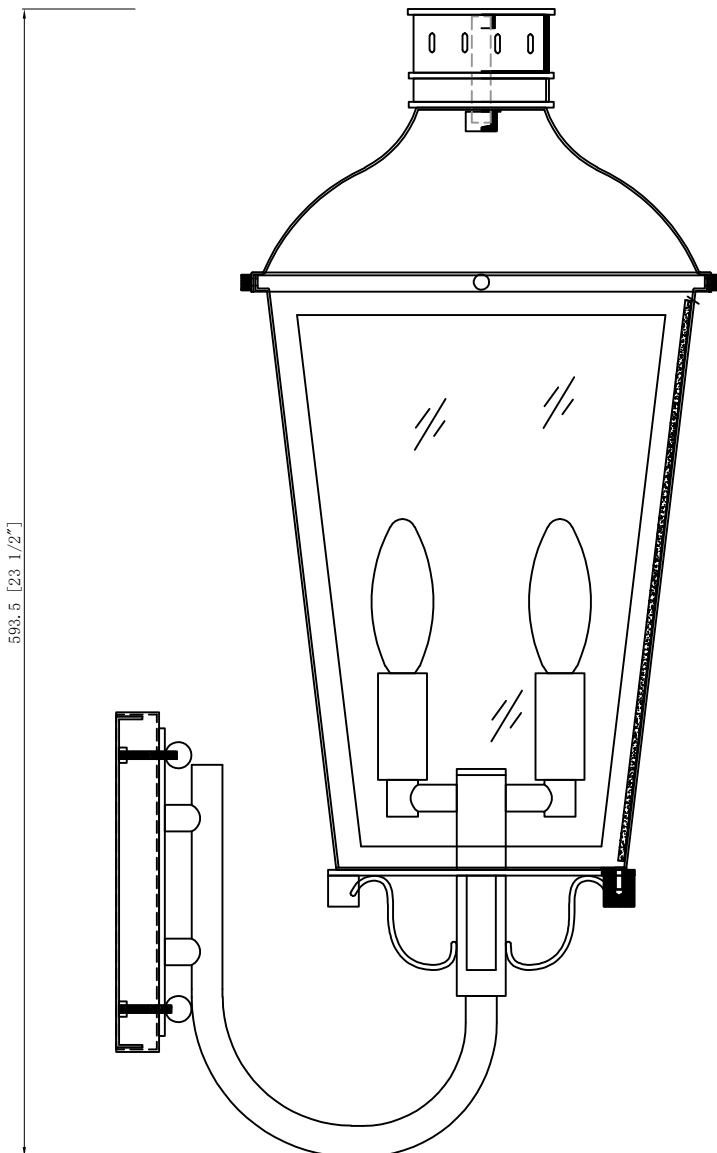



PART NUMBER MODEL #DUM-9802-GE

Part Number

Part Number

- A. (1) Mounting Hardware
- (3) Wire Nut
- (1) Mounting Plate
- (1) Green Ground Screw
- (4) Machine screw
- B. (1) Back plate; 6.9" x 5.4" x 1"H;
XAR9802GEBKP6.9IN
- C. (4) Ball nut; XAR9801GEBANUT
- D. (1) Arm
- E. (3) Socket
- F. (1) Metal frame
- G. (4) Glass; W8" + W5.5" * 11.5"H
XAR9802GEGLA11.5IN
- H. (1) Top cage
- I. (4) Cap nut

