

Power Outside Rigger

700MOPORG2_ 1.6



GENERAL PRODUCT INFORMATION:



This product is suitable for indoor dry locations only.

This product is intended for use with Tech Lighting MonoRail system only.

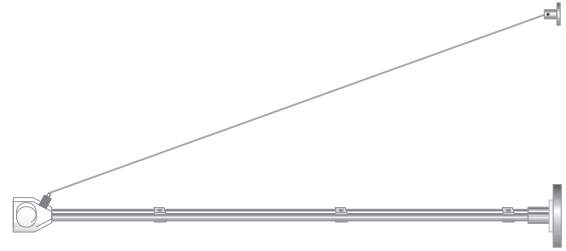

Resizing the Power Outside Riggers

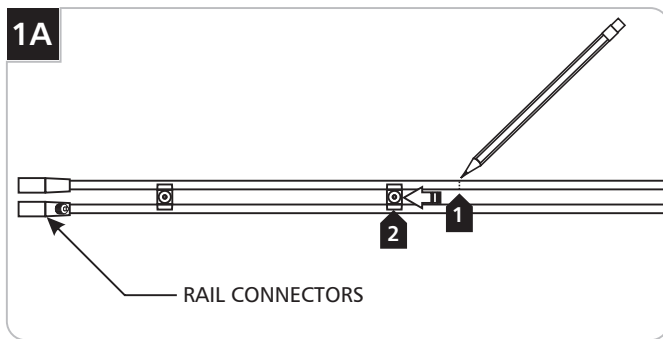

- 1 From the end without the rail connectors, mark the section of the extender that needs to be shortened.
- 2 Slide the separator away from the sections that need to be cut.

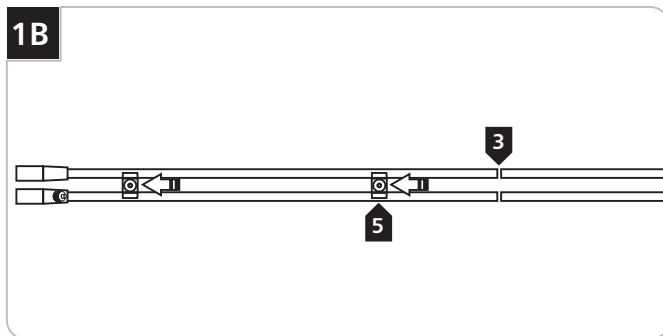

- 3 Cut the marked sections with a hacksaw.
- 4 Clean the inside and outside burrs of the cut section.
- 5 Slide the separators so that they are evenly spaced on the power outside rigger rods.

Installing the Cable Post

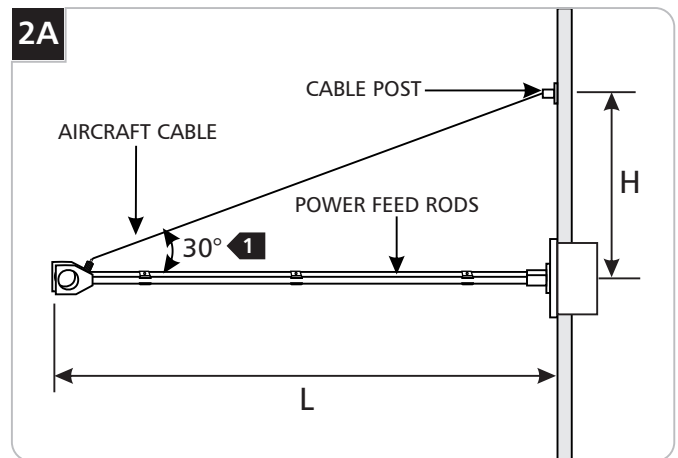

- 1 To properly lock the aircraft cable in position, the cable post should be mounted above the electrical box at minimum of 30° angle between the power feed rods and the aircraft cable. Refer to the charts below for the measurements.

ANGLE	EQUATION FOR HEIGHT (H)
30°	$H = 0.6 \times L$
45°	$H = L$
60°	$H = 1.7 \times L$

LENGTH (L)	(H) FOR 30°	(H) FOR 45°	(H) FOR 60°
36"	21"	36"	62"
24"	14"	24"	42"
12"	7"	12"	21"

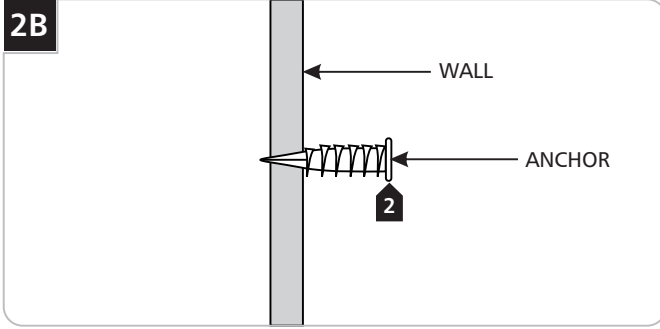

- 1 Mark the location of the cable post onto the wall.
- 2 With a hammer tap the anchor at the marked point into the wall up to the threaded portion.

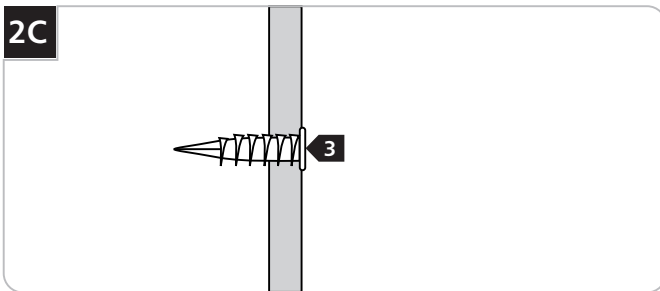

- 3 Screw the anchors in the rest of the way with a Phillips screwdriver.

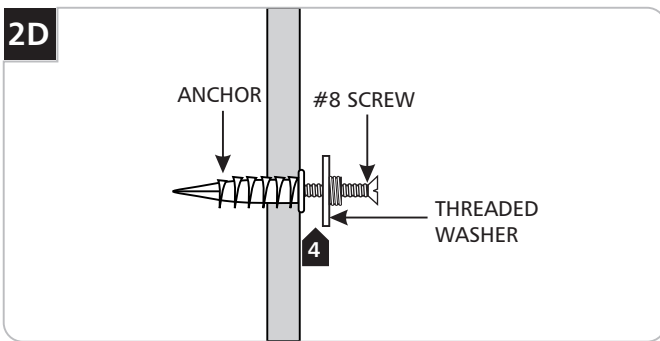

- 4 Attach the threaded washer to the anchor with the #8 screw.

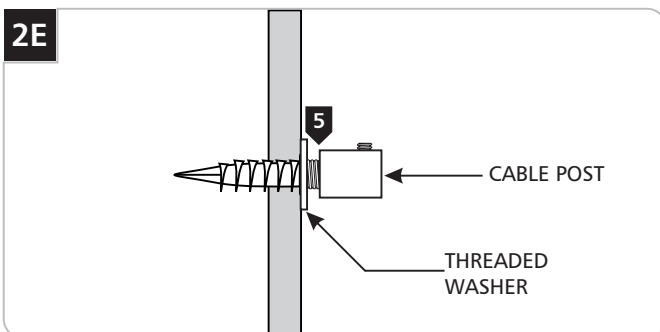

- 5 Screw the cable post to the threaded washer.

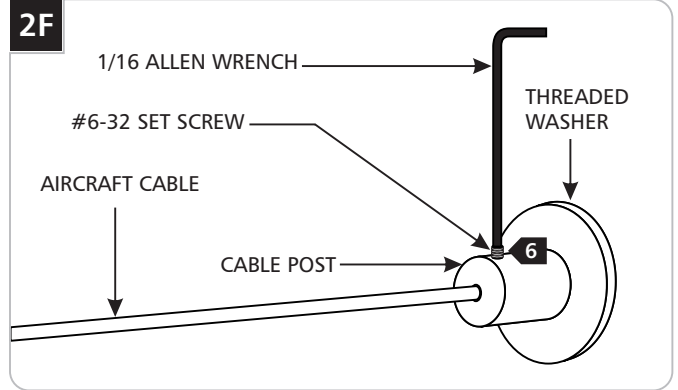

- 6 Feed the aircraft cable into the cable post and tighten the #6-32 set screw with the 1/16 Allen wrench.

Converting the 2" Power Feed Canopy to the 4" Power Feed Canopy

NOTE: Do the following steps only when using the 4" round canopy.

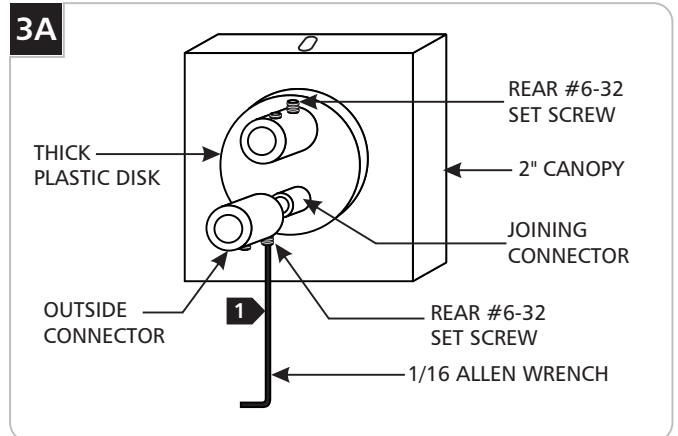

- 1 Loosen the #6-32 set screw on the outside connectors with the 1/16 Allen wrench. Remove the outside connectors.

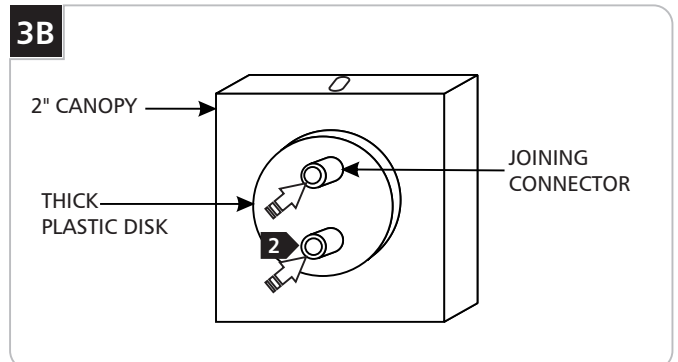

- 2 From the front of the 2" power feed canopy push the joining connectors to disassemble the thick and thin disks from each other.

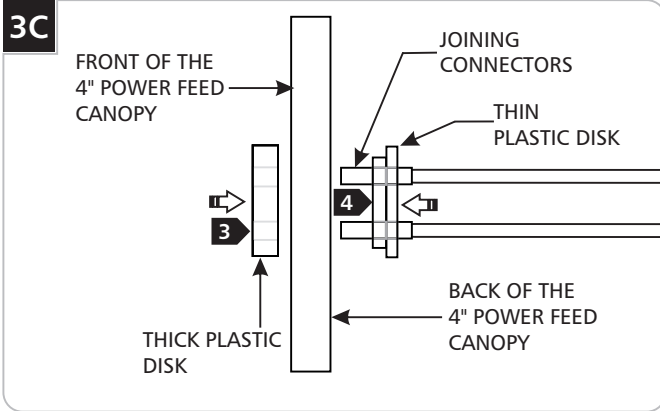

- 3 From back of the 4" power feed canopy place the thin plastic disk with the joining connectors into the canopy center hole.
- 4 From the front of the canopy push the thick plastic connector over the joining connectors. Squeeze both plastic disks together.

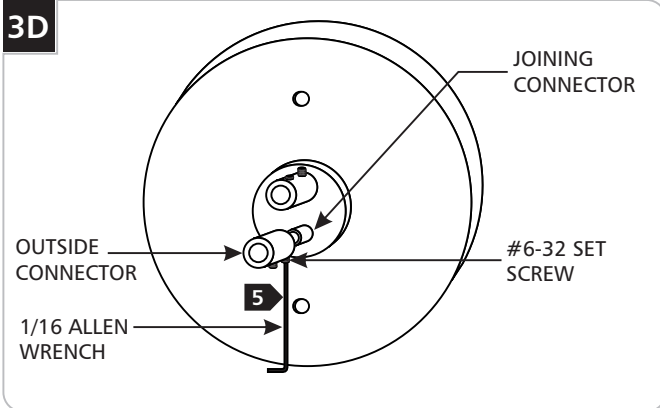

- 5 Push the outside connectors over the exposed joining connectors and tighten the rear #6-32 set screws with the 1/16 Allen wrench.

Installing the 2" Power Outside Rigger Canopy

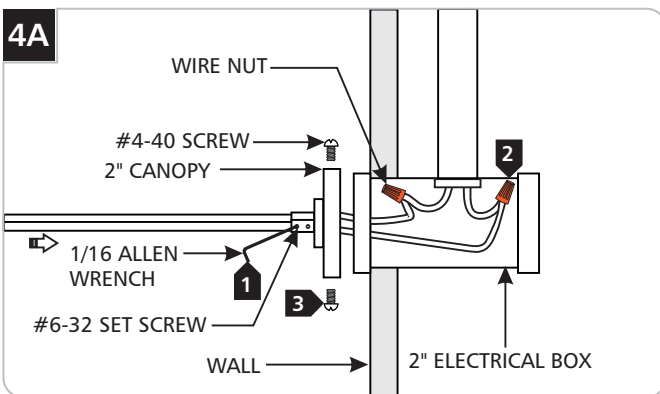

NOTE: The 2" electrical box must be installed prior to these steps. Refer to the 2" electrical box instruction.

NOTE: The low voltage wires must be present in the 2" electrical box prior to these steps. Refer to the remote transformer instruction.

- 1 Push the outside connectors over the exposed joining connectors and tighten the rear #6-32 set screws with the 1/16 Allen wrench.
- 2 Connect the canopy wires to the low voltage wires in the electrical box with the wire nuts.
- 3 Mount the 2" power feed canopy to the 2" electrical box with the two #4-40 screws.

Installing the 4" Power Outside Rigger Canopy

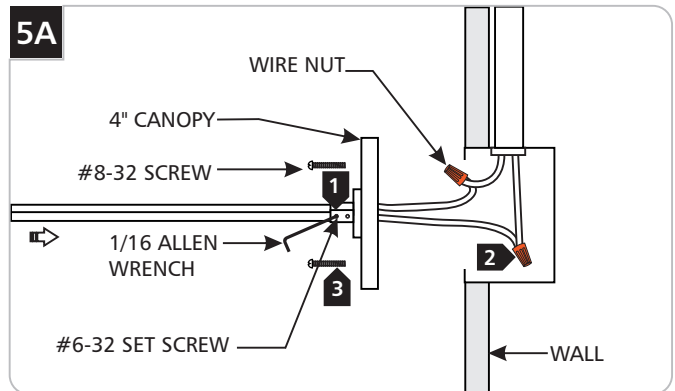

NOTE: Use the provided universal crossbar when the canopy holes do not match with the electrical box holes.

- 1 Push the outside connectors over the exposed joining connectors and tighten the rear #6-32 set screws with the 1/16 Allen wrench.
- 2 Connect the canopy wires to the low voltage wires in the electrical box with the wire nuts.
- 3 Mount the 4" power feed canopy to the electrical box with the two #8-32 screws.

Installing the Aircraft Cable

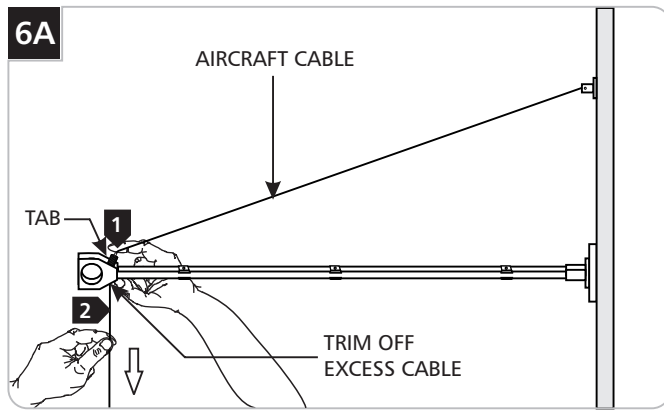

- 1 Push the wire grip tab down and feed the aircraft cable through the hole.
- 2 After adjusting the power feed outside rigger, release the tab to lock the outside rigger in position. Trim off the excess aircraft cable for a nice and neat look.

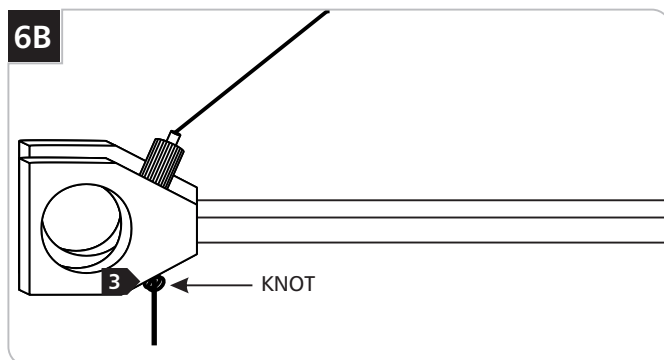

- 3 Put a knot in the aircraft cable beneath the rail connector when the angle is less than 30° or when the aircraft cable slips.

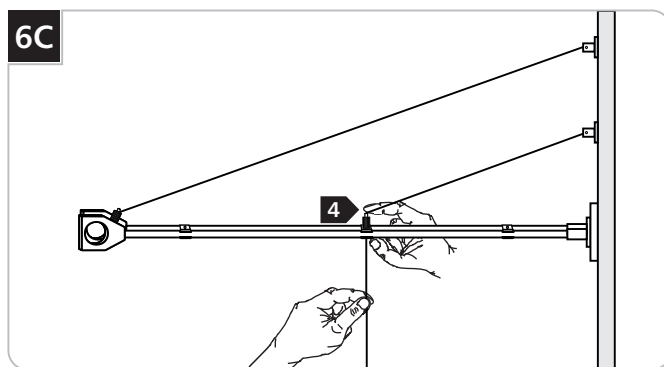

- 4 Power outside riggers with over 36" power rods come with an additional wire grip in the middle of the power feed rods. Repeat the applicable steps for installing the additional wire grip.

Connecting the MonoRail to Power Outside Rigger

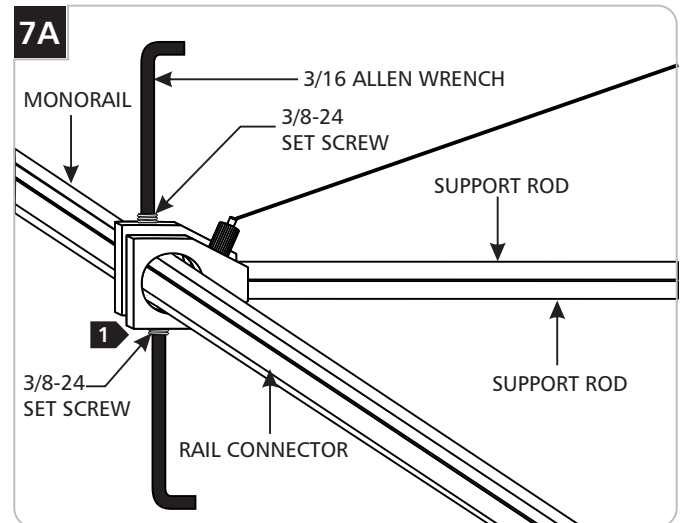

- 1 Insert the MonoRail through the rail connectors hole and fasten the 3/8-24 set screws one on top of the one rail connector and the other one on the bottom of the other rail connector) very tight with the 3/16 Allen wrench.

SAVE THESE INSTRUCTIONS!



7400 Linder Ave, Skokie, IL 60077

847.410.4400

www.techlighting.com

© 2008 Tech Lighting, L.L.C. All rights reserved. The "Tech Lighting" graphic is a registered trademark of Tech Lighting, L.L.C. Tech Lighting reserves the right to change specifications for product improvements without notification.
A Generation Brands Company