

**SAN MARCO
S8620N- __ __ R**



THIS DESIGN IS THE PROPRIETARY
TRADE DRESS/TRADEMARK OF
W SCHONBEK LLC.

SCHONBEK
Signature[™]

SCHONBEK
Signature[™]

MAX <u>60</u> W	110-120 V							

WARNING:

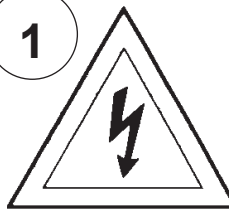
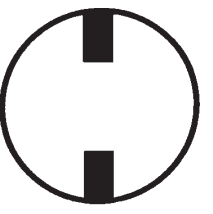
1  

Electrical Danger Turn Power Off

All electrical components must be installed by a licensed electrician in accordance with the National Electric Code and the appropriate local electrical codes.

WARNING: THIS LUMINAIRE MUST BE MOUNTED OR SUPPORTED INDEPENDENTLY OF AN OUTLET BOX.

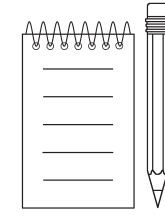
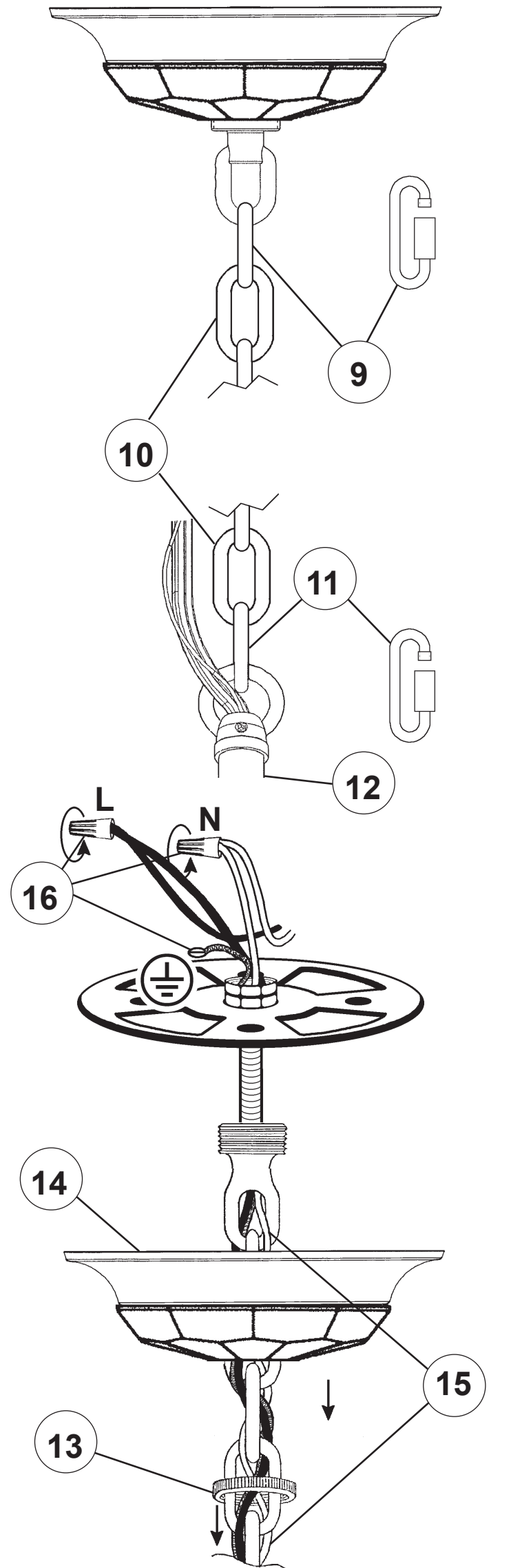
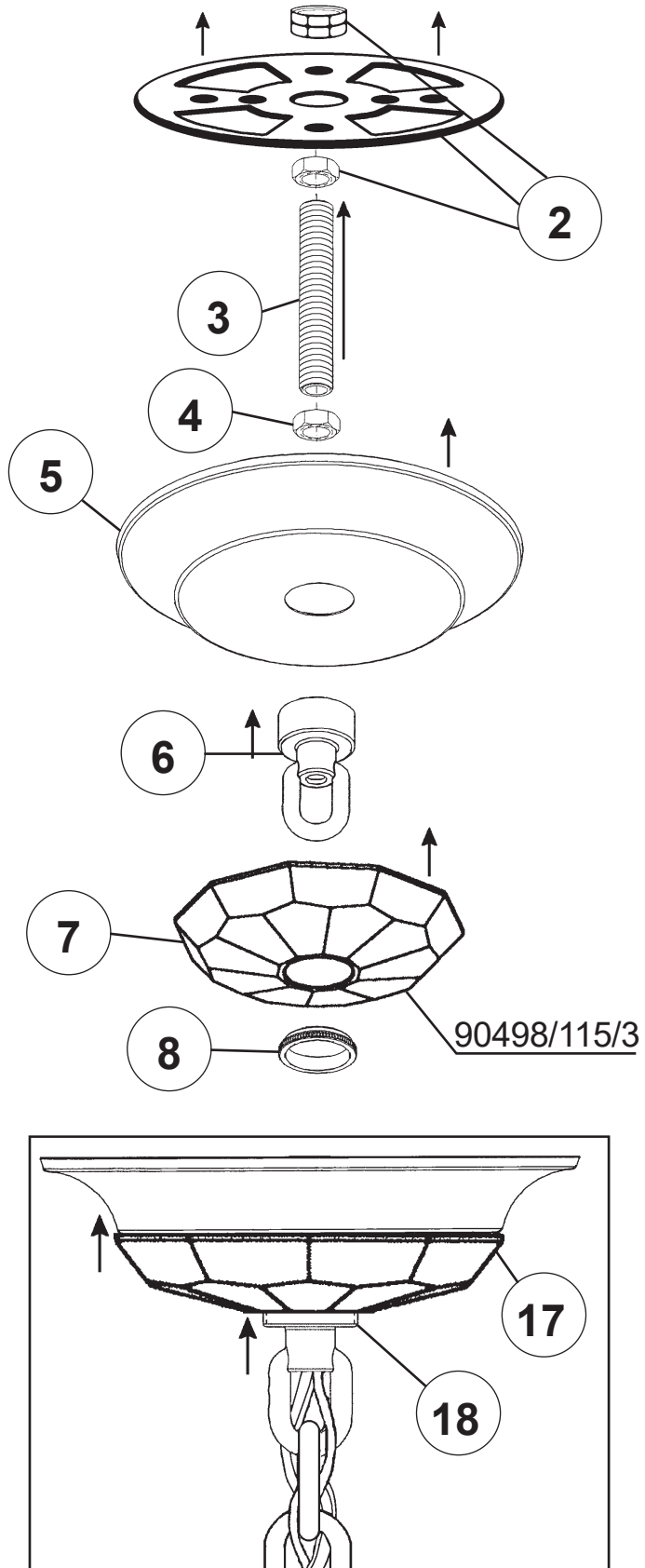

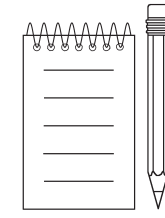
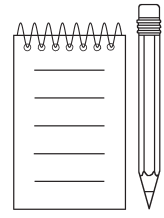

20

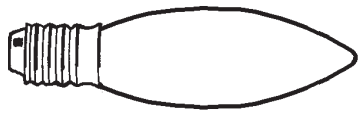

You will need 20 - B10
25 Watts Recommended
60 Watts Max

