

NAPOLI  
S7601N-\_\_ \_\_R

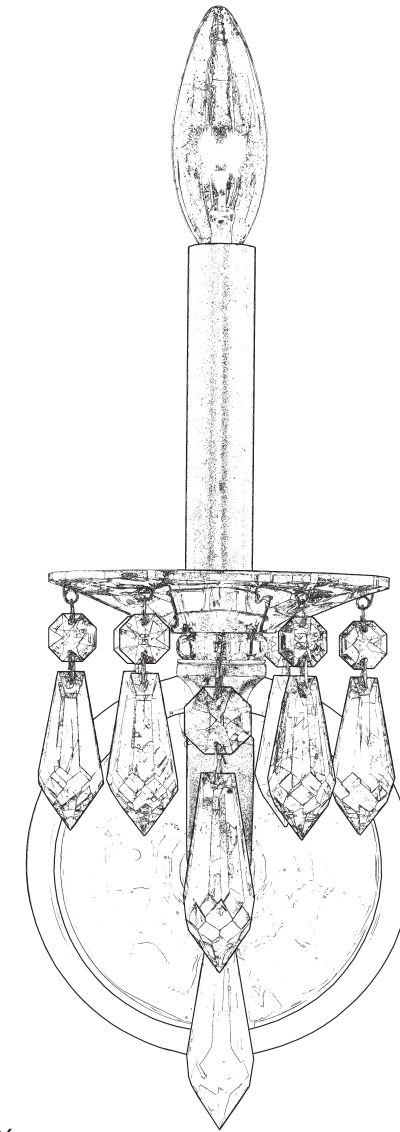

THIS DESIGN IS THE PROPRIETARY  
TRADE DRESS/TRADemark OF  
W SCHONBEK LLC.

SCHONBEK  
*Signature*<sup>TM</sup>

SCHONBEK  
*Signature*<sup>TM</sup>

MAX <b>60</b> W	110-120 V							

**WARNING:**

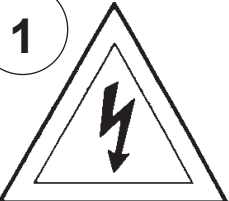
**1**  **Electrical Danger**

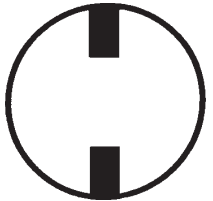
 **Turn Power Off**

All electrical components must be installed by a licensed electrician in accordance with the National Electric Code and the appropriate local electrical codes.

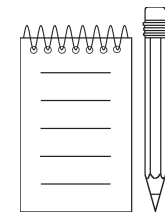
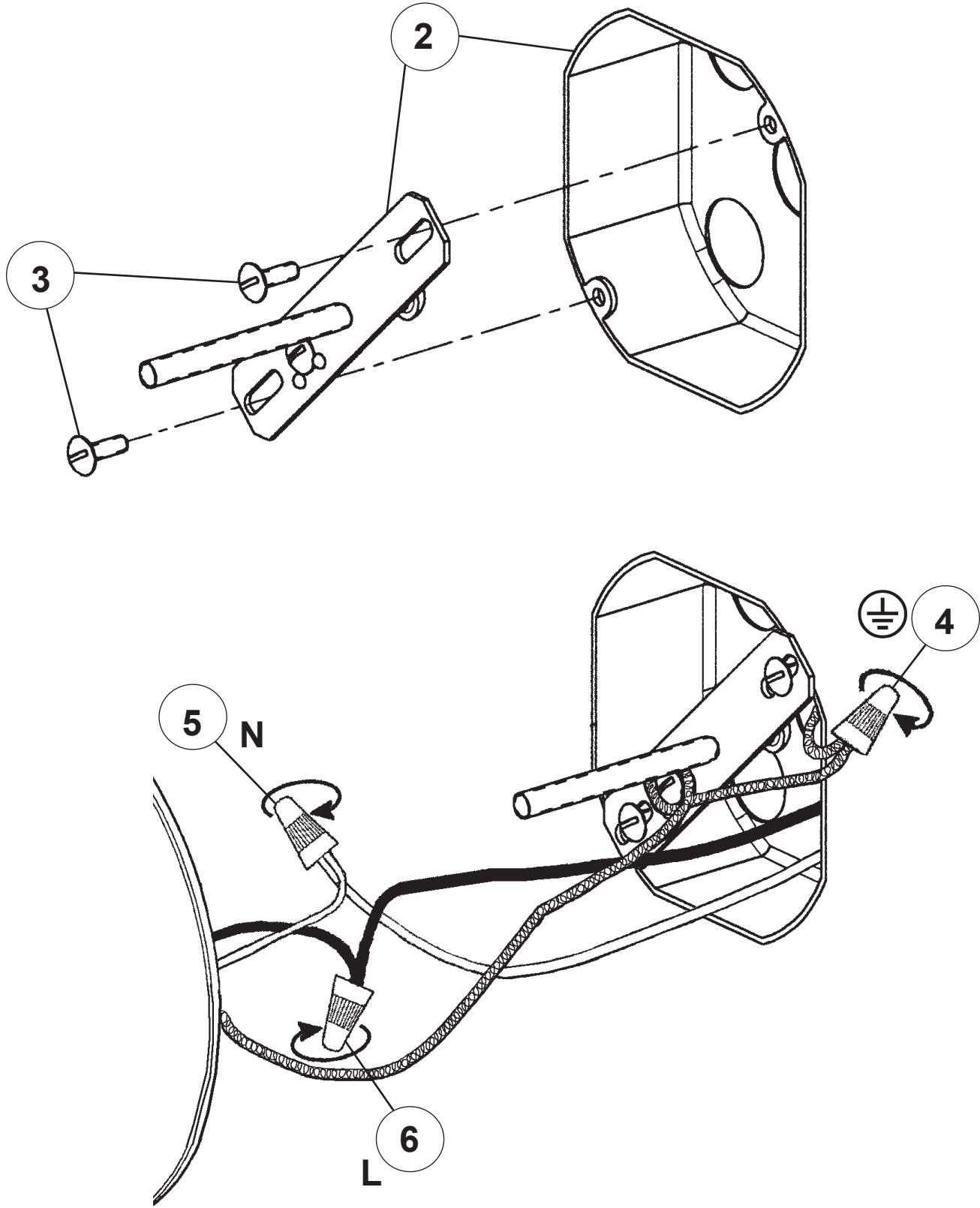

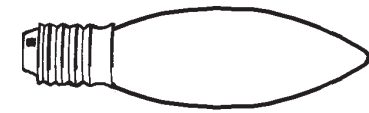

You will need 1 - B10  
25 Watts Recommended  
60 Watts Max

