

ASSEMBLING & INSTALLATION INSTRUCTIONS FOR PRODUCT# 50901 50911 50903 50913 For Ceiling Mount Fixtures

**WARNING! SHUT POWER OFF AT FUSE OR CIRCUIT BREAKER .
ATTENTION! COUPER LE COURANT AU FUSIBLE OU LE DISJONCTEUR .**

ASSEMBLING THE FIXTURE (Fig.1)

1. Shut off the power at the circuit breaker box. Remove old fixture and all hardware from Junction Box.
2. Carefully unpack your new fixture and lay out all the parts on a clear area. Take care not to lose any small parts necessary for installation.
3. Install the light bulbs in accordance with the fixture's specifications. **NOTE: DO NOT EXCEED THE SPECIFIED WATTAGE!**
4. Raise the glass shade (D) to the lamp holder, lock it securely with screw(C) until snug.
5. Thread the two mounting screws about 1/4" into the pre-drilled holes in the single bar spaced the same distance apart as the holes in the fixture canopy.
6. Install the single bar to the Junction Box with the two Box Screws as shown. The side of the single bar marked "GND" must face out. **The junction box is not included.**
7. While holding the lamp(A) towards the ceiling, connect the electrical wires as Shown in Fig.2, making sure that all wire nuts are secured. You may have to wrap the connections with electrical tape. If your outlet has a ground wire (green or bare copper), connect the fixture ground wire to it. Otherwise connect fixture's ground wire directly to the Mounting strap with the green screw provided. After wires are connected, tuck them carefully inside the Junction Box.
8. Attach the fixture canopy on to the junction box, aligning screws on single bar with mounting holes in canopy and lock it securely with ball nut (B).

Your installation is now complete Return power to the junction box and test the fixture.

Fig.1

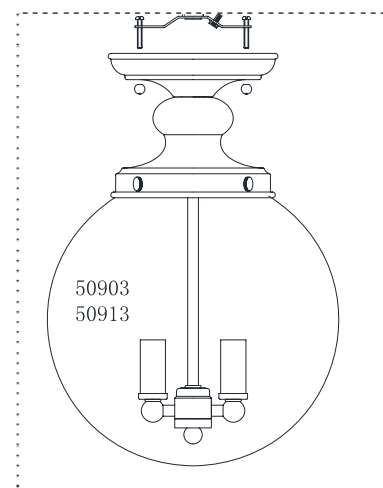
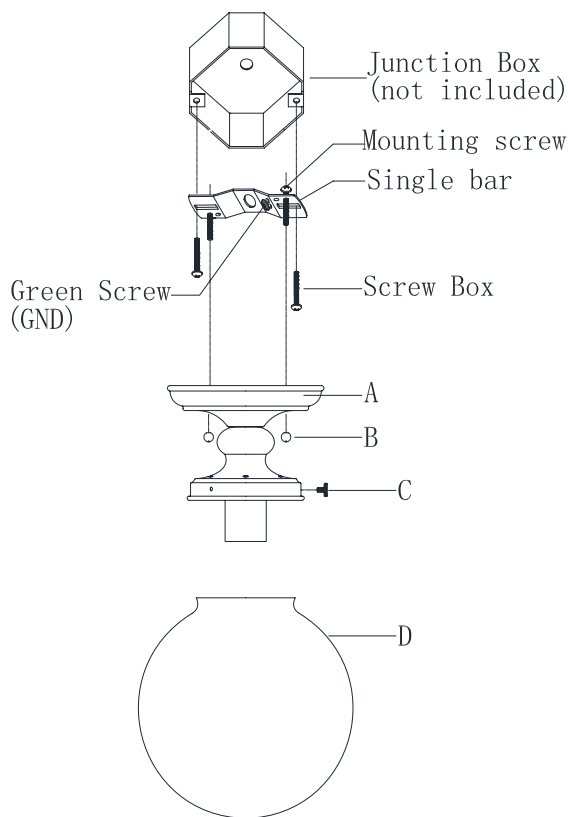





Fig.2

FIXTURE WIRES Black or Smooth		FIXTURE WIRES White or Ribbed		FIXTURE WIRES Bare Copper (Ground)	
HOUSE WIRES Black (Hot)		HOUSE WIRES White (Neutral)		HOUSE WIRES Green or Bare Copper (Ground)	