

# Ceiling LED Pendants

**PD9108**  
INSTALLATION SHEET

## START FROM HERE

- Make sure power is completely off at the fuse box.
- Have your fixture installed by a qualified licensed electrician
- Prepare everything in a clear area.
- Wear gloves at all times during this installation.
- Read instructions carefully before you start assembly.
- Keep this instruction sheet for future reference.

**Technical Support:** 1-877-452-6858

### Please Note:

- All Kuzco LED fixtures come with pre-wired LED module(s).
- Unless instructed to do so, please do not touch any part of the LED module(s) as any unnecessary contact with the module could cause permanent damage.
- For dimming, an ELV (Electronic Low Voltage) type of dimmer is required.

- 1.** Remove the fixture from its original packaging. Remove the canopy mounting plate (**1c**) from within the canopy (**2a**) by removing the decorative nuts (**2c**). Secure the mount plate (with canopy screws facing downward) to the reinforced junction box (**1a**) using screws (**1f**) provided in the hardware package.
- 2.** To change fixture height, shorten or lengthen wire by removing set screw (**2b** from canopy (**2a**) and push or pull wire to your desired length. Secure set screw (**2b**) in canopy (**2a**) to lock wire in place.
- 3.** You are now ready to mount the canopy (**2a**) to the mounting plate (**1c**). First connect all wires (**1b**) correctly, black to black "L", white to white "N" and the ground to ground with the provided marrets from the hardware package. Align the threaded screws (**1d**) hanging downward from the mounting plate to the holes inside the canopy (**2a**). Push the canopy up towards the ceiling so the two screws (**1d**) point through the holes in the canopy. You can then screw on the decorative nuts (**2c**) onto the threaded studs (**1d**) pointing through the canopy (**2a**). This will secure the canopy to the mounting plate.
- 4.** You have now completed the installation of your fixture, enjoy.

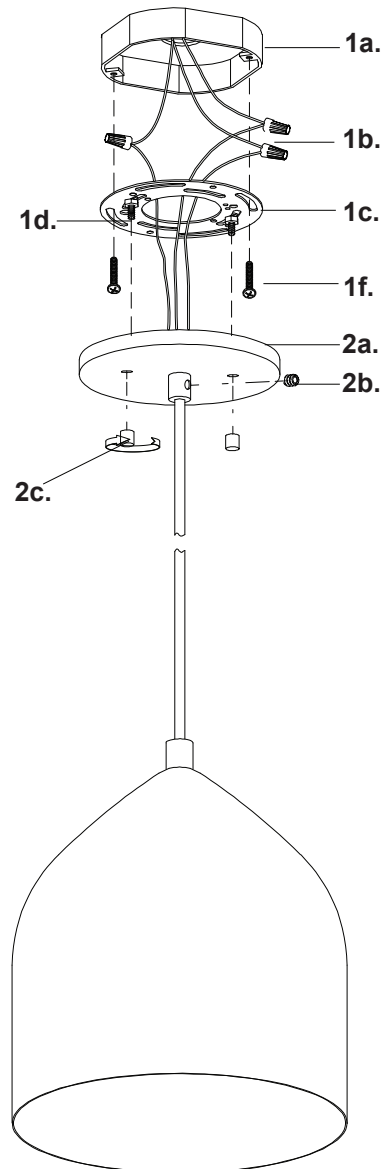

KUZCO

19054 28th Avenue Surrey, BC Canada V3Z 6M3  
T: 604 538 7162 TF: 1-855 85 KUZCO F: 604 538 7196  
W: kuzcolighting.com  
20190117