

**ATTACH YOUR RECEIPT HERE**

**Serial Number** \_\_\_\_\_ **Purchase Date** \_\_\_\_\_



Questions, problems, missing parts? Before returning to your retailer, call our customer service department at **1-866-558-5706**, 8 a.m. - 4 p.m., EST, Monday - Friday.

# PACKAGE CONTENTS

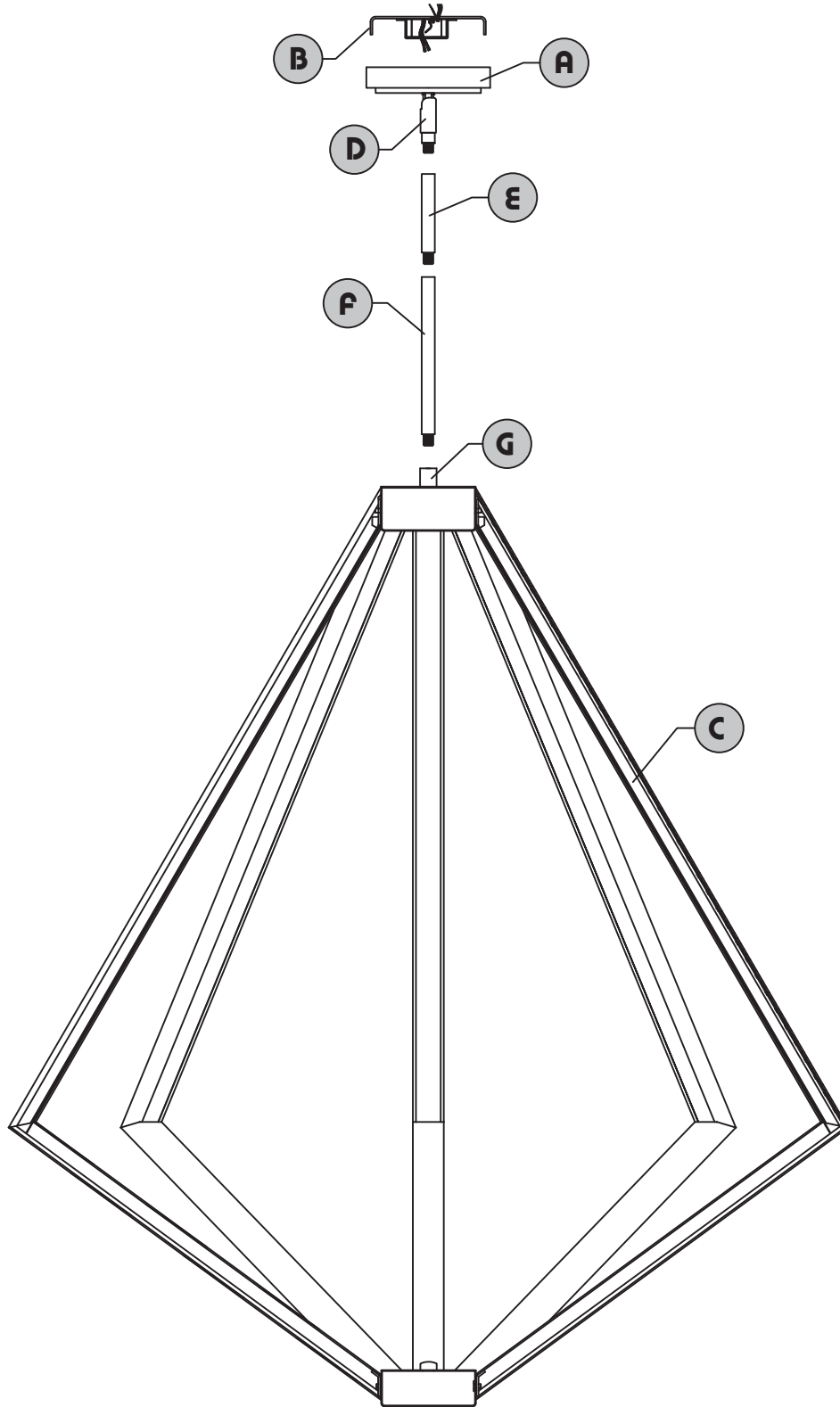

| PART | DESCRIPTION      | QTY. |
|------|------------------|------|
| A    | Canopy           | 1    |
| B    | Mounting Bracket | 1    |
| C    | LED Assembly     | 1    |
| D    | Swivel Connector | 1    |

| PART | DESCRIPTION       | QTY. |
|------|-------------------|------|
| E    | 6" Threaded Pipe  | 2    |
| F    | 12" Threaded Pipe | 2    |
| G    | Coupling          | 1    |

## HARDWARE CONTENTS

AA



Wire  
Connector  
Qty: 3

BB

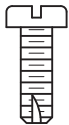

Short  
Machine  
Screw  
Qty: 2

CC



Canopy  
Screw  
Qty: 2

DD

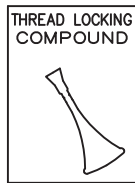

Thread Locking  
Compound  
Qty: 1



## SAFETY INFORMATION

Please read and understand this entire manual before attempting to assemble, operate or install the product.



### WARNING

- **IMPORTANT:** NEVER attempt any work without shutting off the electricity.
- Go to the main fuse box, or circuit breaker, in your home. Place the main power switch in the "OFF" position and unscrew the fuse(s), or switch "OFF" the circuit breaker switch(es), that control the power to the fixture or room that you are working on.
- Place the wall switch in the "OFF" position. If the fixture to be replaced has a switch or pull chain, place those in the "OFF" position.
- Do not touch hot LED.
- The LED light output is strong enough to injure human eyes. Precautions must be taken to prevent looking directly at the LEDs with unaided eyes for more than a few seconds.
- California Proposition 65



**WARNING:** This product can expose you to lead, which is known to the State of California to cause cancer, birth defects or other reproductive harm. For more information go to [www.p65warnings.ca.gov](http://www.p65warnings.ca.gov)

### CAUTION

- Read and understand all instructions and illustrations completely before proceeding with assembly and installation of this fixture.
- If you have any doubts about how to install this lighting fixture, or if the fixture fails to operate completely, please contact a qualified licensed electrical contractor.
- All parts must be used as indicated in these instructions. Do not substitute any parts, leave parts out, or use any parts that are worn out or broken. Failure to obey this instruction could invalidate the UL listing, C.S.A. certification, and/or ETL listing of this fixture.
- This fixture is intended for installation in accordance with the National Electric Code (NEC) and all local code specifications.
- This fixture is for indoor use only.
- Use ONLY the supplied LED driver to power fixture.
- Driver cable is not intended for use through or concealed behind walls, floors, or ceilings.
- This fixture is dimmable when using an **electronic low voltage (ELV)** dimmer. Note: dimmers that specify use with LED, but are not ELV, are NOT sufficient. They are designed to work with LED "bulbs" not integrated LED fixtures.

## PREPARATION

Before beginning assembly of product, make sure all parts are present. Compare parts with package contents list. If any part is missing or damaged, do not attempt to assemble the product.

### Estimated assembly time: 30 minutes to 1 hour

Tools Required for Assembly (not included): Phillips screwdriver, flathead screwdriver, wire strippers, electrical tape, ladder, safety glasses.

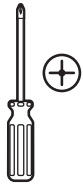

Phillips screwdriver



Flathead screwdriver

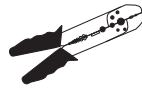

Wire strippers

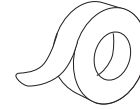

Electrical tape



Ladder



Safety goggles

## ASSEMBLY INSTRUCTIONS

1. Place a drop of locking compound (DD) on the threads on the threaded pipes. Screw 6 in. threaded pipe (E) onto 12 in. threaded pipe (F). Connect the assembled pipes onto coupling (G). Finally, screw swivel connector (D) onto 6 in. threaded pipe (E).

**Note:** The electrical cable will need to get pulled through the individual parts as they are installed on this and later steps.

**Note:** The hanging height for this fixture is adjustable. Add or subtract threaded pipes to achieve the desired height.

### Hardware Used

**DD** Thread Locking Compound



x 1

4

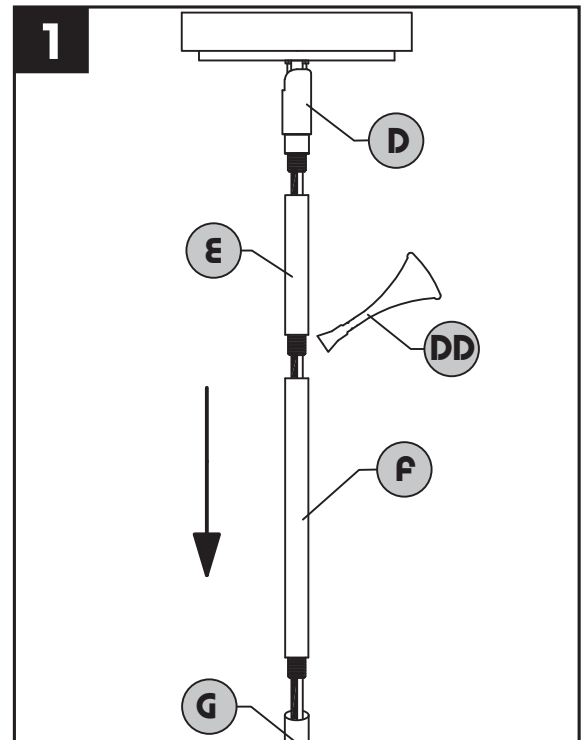

## ASSEMBLY INSTRUCTIONS

### 2. Wire connection guide (outlet box to driver):

Ground wire:

For installation in the United States: Wrap ground wire from outlet box around ground screw preassembled on mounting bracket (B) no less than 2 in. from wire end. Tighten ground screw.

Supply wires:

- Connect the Neutral (White) supply wire from the outlet box to the Neutral driver input wire (White).
- Connect the Live (Black) supply wire from the outlet box to the Live driver input wire (BLACK).

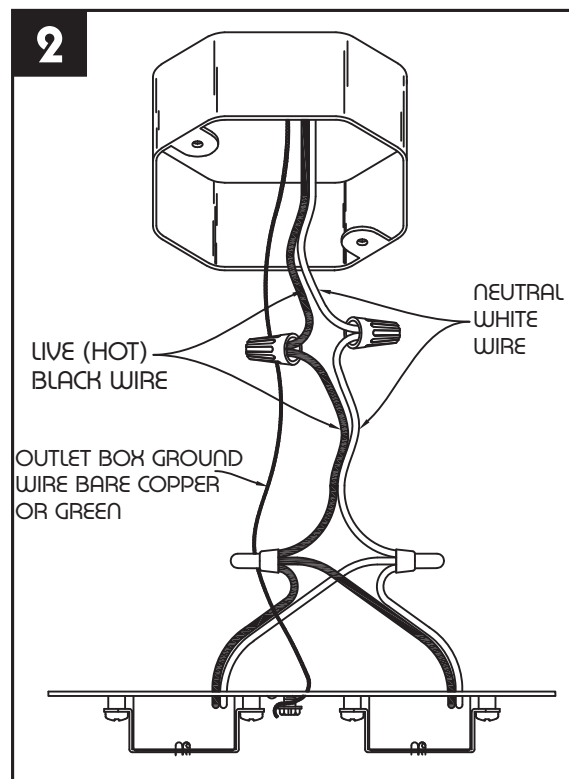

3. Orient the mounting bracket (B) so that the arms are facing away from the outlet box (not included). Connect the mounting bracket (B) to the outlet box with short machine screws (BB).

### Hardware Used

**BB** Short Machine Screw  x 2

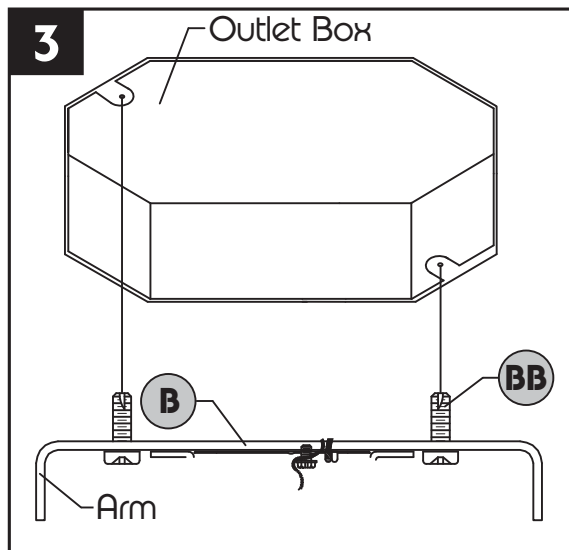

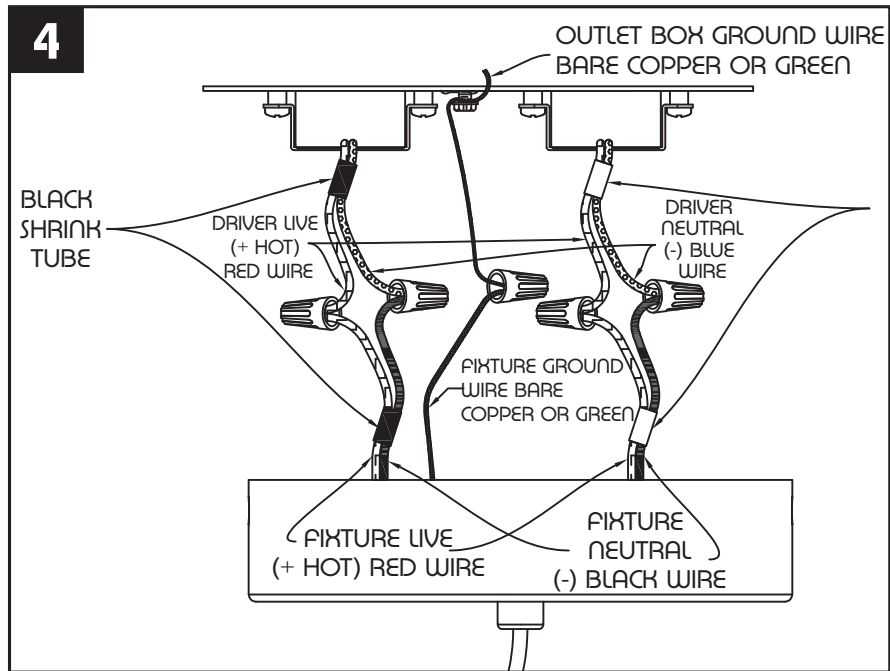

#### 4. Wire connection guide (fixture to driver):

Ground wire: Connect fixture ground wire to the outlet ground wire that has been attached to the mounting bracket ground screw.

Supply wires: **\*\*NOTE:** Connect one pair of fixture wires to each driver. Wire "pairs" are bundled by shrink tubing.

- Connect the Neutral (Blue) driver output wire to the Neutral (Black) fixture wire.
- Connect the Live (Red) driver output wire to the Live (Red) fixture wire.

#### 5. Pass canopy (A) over the arms protruding from mounting bracket (B) then secure in place with canopy screws (CC).

#### Hardware Used

-  Canopy Screw  x 2

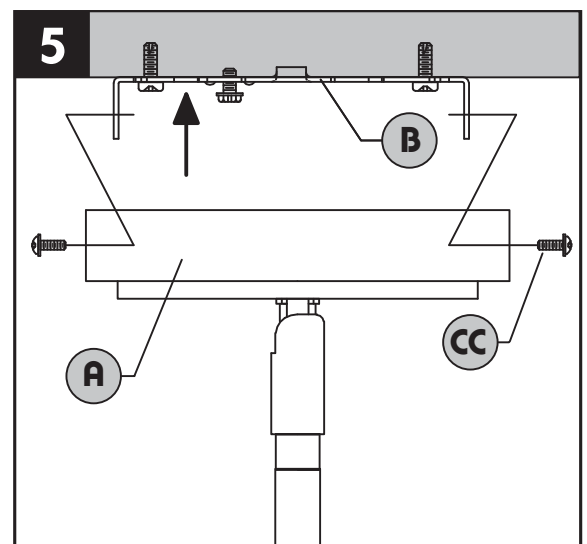

## CARE AND MAINTENANCE

- Always be certain that electric current is turned off before cleaning this item.
- Use a soft, moist cloth with mild non-abrasive soap to clean fixture. Never use glass cleaner on fixture, as it will damage the metal finish.

## TROUBLESHOOTING

| PROBLEM                 | POSSIBLE CAUSE                       | CORRECTIVE ACTION |
|-------------------------|--------------------------------------|-------------------|
| Fixture does not light. | 1. Fixture may be wired incorrectly. | 1. Check wiring.  |

## LIMITED WARRANTY ON KICHLER® ÉLAN BRAND LIGHT FIXTURES

Kichler Lighting LLC warrants its light fixtures to the original consumer purchaser to be free from defects in material and workmanship for the applicable period specified below:

Kichler® élan Light Fixtures

One (1) year from the date of purchase by the original consumer purchaser.

Kichler® élan Light Fixtures with LED Light Engines and Electrical Components

three (3) years from the date of purchase by the original consumer purchaser on the Light Engine and all other electrical components.

What We Will Do

Kichler Lighting LLC will repair or replace, free of charge, during the applicable warranty period (as described above), any light fixture that proves defective in material and/or workmanship under normal installation, use and service. If repair or replacement is not practical, Kichler Lighting LLC may elect to refund the purchase price in exchange for the return of the product. These are your exclusive remedies.

What Is Not Covered

Polished brass product finishes and non-LED light bulbs carry no warranty. Any labor charges incurred by the original consumer purchaser to repair or replace this product are not covered by this warranty. Kichler Lighting LLC shall not be liable for any damage to the product resulting from reasonable wear and tear, voltage overload, outdoor use (where the annual average ambient temperature is below 27° or above 95° Fahrenheit), misuse (including use of the product for an unintended application), abuse, neglect or improper or incorrectly performed installation, maintenance or repair, including failure to follow the applicable care and cleaning instructions. Kichler Lighting LLC recommends using a professional electrician for all installation and repair of light fixtures. We also recommend that you use only genuine Kichler® replacement parts.

What You Must Do to Obtain Warranty Service or Replacement Parts

A warranty claim may be made, and replacement parts may be obtained by contacting the distributor from whom you purchased the light fixture. If the distributor is not available, please call 866-558-5706 or contact us by mail as follows (please include your model number and date of purchase):

## WARRANTY (continued)

Kichler Lighting LLC  
7711 East Pleasant Valley Rd  
Cleveland, OH 44161-8010

Proof of purchase (original sales receipt) from the original purchaser must be made available to Kichler Lighting LLC for all warranty claims.

### Limitation on Duration of Implied Warranties

TO THE EXTENT PERMITTED BY LAW, ANY IMPLIED WARRANTY, INCLUDING THE IMPLIED WARRANTIES OF MERCHANTABILITY AND OF FITNESS FOR A PARTICULAR PURPOSE, IS LIMITED TO THE STATUTORY PERIOD OR THE DURATION OF THIS WARRANTY, WHICHEVER IS SHORTER. Some states/provinces do not allow limitations on how long an implied warranty lasts, so the above limitation may not apply to you.

### Limitation of Special, Incidental or Consequential Damages

KICHLER LIGHTING LLC SHALL NOT BE LIABLE FOR ANY SPECIAL, INCIDENTAL OR CONSEQUENTIAL DAMAGES (INCLUDING LABOR CHARGES TO REPAIR, REPLACE, INSTALL OR REMOVE THIS PRODUCT), WHETHER ARISING OUT OF BREACH OF ANY EXPRESS OR IMPLIED WARRANTY, BREACH OF CONTRACT, TORT, OR OTHERWISE. KICHLER LIGHTING LLC SHALL NOT BE LIABLE FOR ANY DAMAGE TO THE PRODUCT RESULTING FROM REASONABLE WEAR AND TEAR, OVERLOAD, OUTDOOR USE (WHERE THE ANNUAL AMBIENT TEMPERATURE IS BELOW 27° OR ABOVE 95° FAHRENHEIT), MISUSE (INCLUDING USE OF THE PRODUCT FOR AN UNINTENDED APPLICATION), ABUSE, NEGLIGENCE OR IMPROPER OR INCORRECTLY PERFORMED INSTALLATION, MAINTENANCE OR REPAIR, INCLUDING FAILURE TO FOLLOW THE APPLICABLE INSTALLATION, CARE AND CLEANING INSTRUCTIONS. Some states/provinces do not allow the exclusion or limitation of special, incidental or consequential damages, so the above limitations and exclusions may not apply to you. Notice to residents of the State of New Jersey: The provisions of this warranty, including its limitations, are intended to apply to the fullest extent permitted by the laws of the State of New Jersey.

### Additional Rights

This warranty gives you specific legal rights, and you may also have other rights which vary from state/province to state/province.

This is Kichler Lighting LLC's exclusive written warranty and the warranty is not transferable.



# REPLACEMENT PART LIST

For replacement parts, call our customer service department at **1-866-558-5706**,  
8 a.m. - 4 p.m., EST, Monday - Friday.

| PART | DESCRIPTION         | PART #      |
|------|---------------------|-------------|
| E    | 6" Threaded Pipe    | PIPEX06-MBK |
| F    | 12" Threaded Pipe   | PIPEX12-MBK |
| AA   | Wire Connector      | WC001       |
| BB   | Short Machine Screw | SCR832X050  |
| CC   | Canopy Screw        | CS84087     |

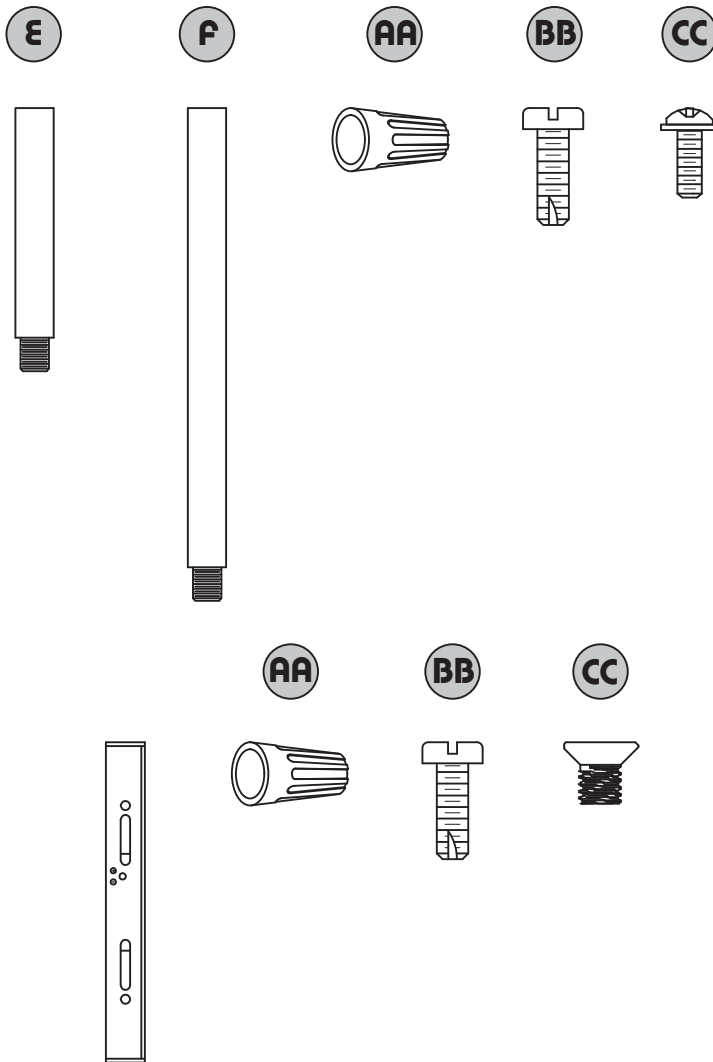

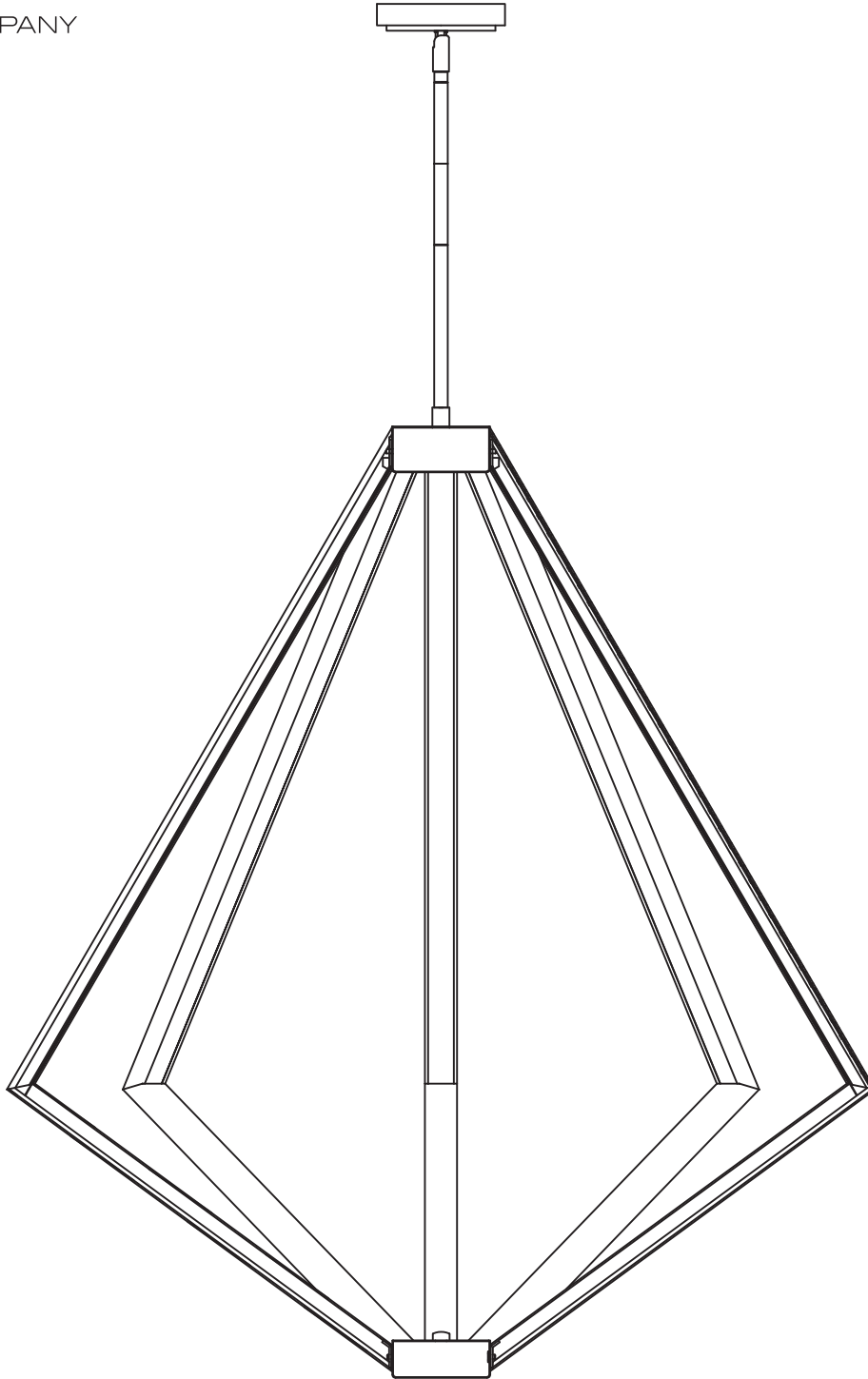

**JOIGNEZ VOTRE REÇU ICI**

**Numéro de série** \_\_\_\_\_ **Date d'achat** \_\_\_\_\_



Des questions, des problèmes, des pièces manquantes? Avant de retourner l'article au détaillant, appelez notre service à la clientèle au **1 866 558-5706**, entre 8 h et 16 h (HNE), du lundi au vendredi.

# CONTENU DE L'EMBALLAGE

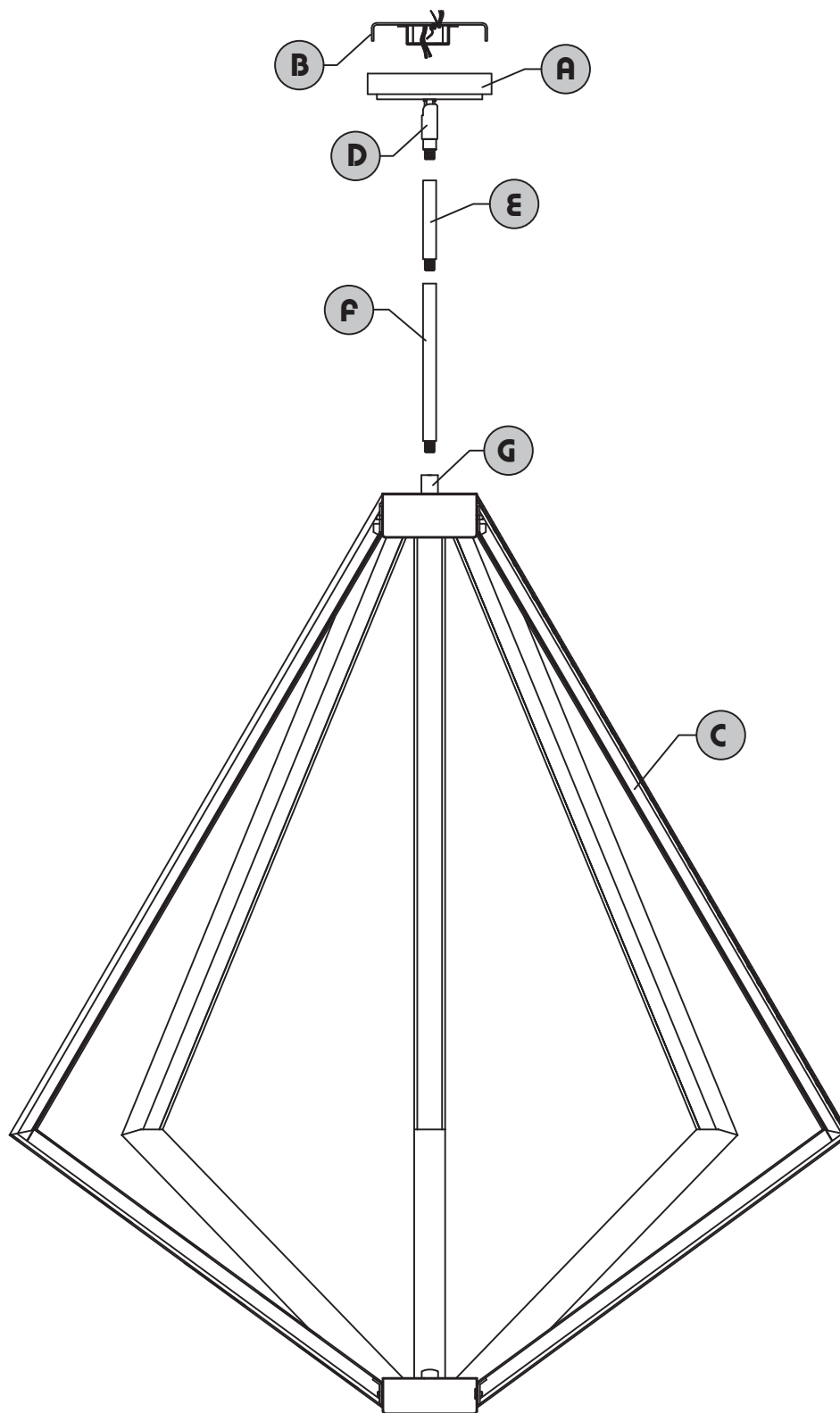

| PIÈCE | DESCRIPTION         | QTÉ. |
|-------|---------------------|------|
| A     | Pavillon            | 1    |
| B     | Support de fixation | 1    |
| C     | Ensemble DEL        | 1    |
| D     | Raccord pivotant    | 1    |

| PIÈCE | DESCRIPTION            | QTÉ. |
|-------|------------------------|------|
| E     | Tube fileté de 15,2 cm | 2    |
| F     | Tube fileté de 30,5 cm | 2    |
| G     | Accouplement           | 1    |

## QUINCAILLERIE INCLUSE

AA



Capuchon  
connexion  
Qté : 3

BB

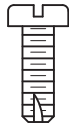

Short  
Machine  
Screw  
Qté : 2

CC



Canopy  
Screw  
Qté : 2

DD



Adhésif  
frein-filet



## CONSIGNES DE SÉCURITÉ

Veillez vous assurer de lire et de comprendre l'intégralité du présent guide avant d'assembler, d'utiliser ou d'installer ce produit.



## AVERTISSEMENT

- **IMPORTANT** : Coupez l'électricité avant TOUTE manipulation.
- Accédez au panneau central de disjoncteurs ou de fusibles de votre demeure. Placez l'interrupteur principal en position d'arrêt « OFF » et dévissez le(s) fusible(s), ou placez en position « OFF » le(s) interrupteur(s) du disjoncteur qui contrôle l'alimentation électrique du luminaire ou de la pièce où vous travaillez.
- Placez l'interrupteur mural en position d'arrêt « OFF ». Si le luminaire à remplacer est doté d'un interrupteur à bouton ou à chaîne, placez-le en position d'arrêt « OFF ».
- Ne touchez pas les DEL chaudes.
- La lumière produite par les DEL est assez puissante pour blesser les yeux humains. Des précautions doivent être prises pour éviter de recevoir directement dans les yeux non protégés la lumière des DEL pendant plus de quelques secondes.
- Proposition 65 de la Californie.



**AVERTISSEMENT:** ce produit peut vous exposer au plomb, ce qui est reconnu par l'État de Californie comme cause de cancer, d'anomalies congénitales ou d'autres dommages à la reproduction. Pour plus d'informations, visitez [www.p65warnings.ca.gov](http://www.p65warnings.ca.gov)

## ATTENTION

- Prenez soin de lire et de comprendre l'intégralité des instructions et des illustrations avant de commencer l'assemblage et l'installation de ce luminaire.
- Si vous avez des doutes à propos de l'installation, ou si le luminaire ne fonctionne pas correctement, veuillez contacter un électricien qualifié agréé.
- Toutes les pièces doivent être utilisées tel qu'il est indiqué dans ces instructions. Ne remplacez pas les pièces, n'en laissez pas de côté et ne les utilisez pas si elles sont usées ou brisées. Le non-respect de ces instructions peut annuler les homologations UL, CSA et/ou ETL de ce luminaire.
- Ce luminaire est conçu pour une installation en conformité avec le code électrique national des États-Unis (National Electric Code - NEC) et avec toutes les spécifications du code électrique local.
- Ce luminaire est conçu pour une utilisation en intérieur uniquement.
- Utilisez **UNIQUEMENT** le pilote de DEL fourni pour faire fonctionner le luminaire.
- Le câble du pilote n'est pas conçu pour une utilisation à travers ou dissimulée derrière les murs, les sols ou les plafonds.
- Ne PAS allumer le luminaire si certaines lumières ne fonctionnent pas ou fonctionnent mal ou si le luminaire se révèle endommagé de toute autre manière.
- Este accesorio es regulable cuando se usa un atenuador electrónico de bajo voltaje (ELV). Nota: los reguladores que utilizan LED, pero no son ELV, NO son suficientes. Están diseñados para funcionar con "bombillas" LED y no con dispositivos LED integrados.

## PREPARATION

Avant de commencer l'assemblage du produit, assurez-vous d'avoir toutes les pièces. Comparez les pièces dans l'emballage avec la liste du contenu. S'il y a des pièces manquantes ou endommagées, ne tentez pas d'assembler le produit.

### Temps d'assemblage approximatif : de 30 à 60 minutes

Outils requis pour l'assemblage (non fournis) : tournevis cruciforme, tournevis à tête plate, pinces à dénuder, ruban isolant, échelle, lunettes de sécurité.

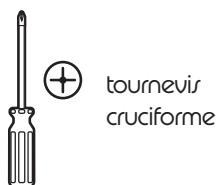

pinces à dénuder



ruban isolant



échelle



lunettes de sécurité

## INSTRUCTIONS POUR L'ASSEMBLAGE

1. Placez une goutte d'adhésif frein-filet (DD) sur le filetage des tubes filetés. Vissez le tube fileté de 15,24 cm (E) au tube fileté de 30,48 cm (F). Raccordez les tubes assemblés au raccord (G). Vissez l'anneau de suspension du luminaire (D) sur le tube fileté de 30,48 cm (E).

**Remarque :** le câble électrique devra être tiré à travers les différents éléments au fur et à mesure de leur montage, lors de cette étape et des suivantes.

**Remarque :** La hauteur de suspension de ce luminaire est réglable. Ajoutez ou enlevez des tubes filetés pour obtenir la hauteur souhaitée.

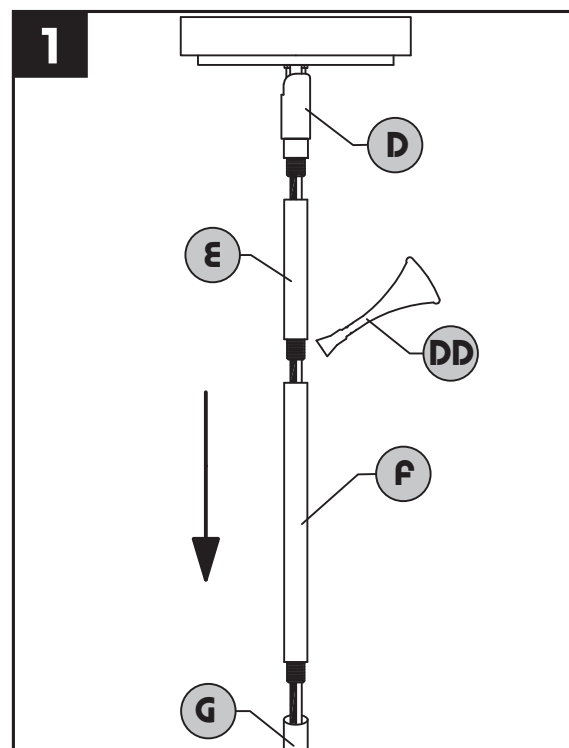

### Quincaillerie utilisée

**DD** Adhésif frein-filet



x 1

## INSTRUCTIONS POUR L'ASSEMBLAGE

2. Guide de raccordement électrique (de la boîte de sortie au pilote) :

Fil de mise à la terre :

Pour une installation aux États-Unis : enroulez le fil de terre provenant de la boîte de sortie autour de la vis de mise à la terre préassemblée sur le support de fixation (B), à au moins 5 cm (2 po) de l'extrémité du fil. Serrez la vis de mise à la terre.

Fils d'alimentation :

- Connectez le fil Neutre de l'alimentation (Blanc) provenant de la boîte de sortie au fil Neutre d'entrée du pilote (Blanc).
- Connectez le fil de Phase de l'alimentation (Noir) provenant de la boîte de sortie au fil de Phase d'entrée du Pilote (NOIR).

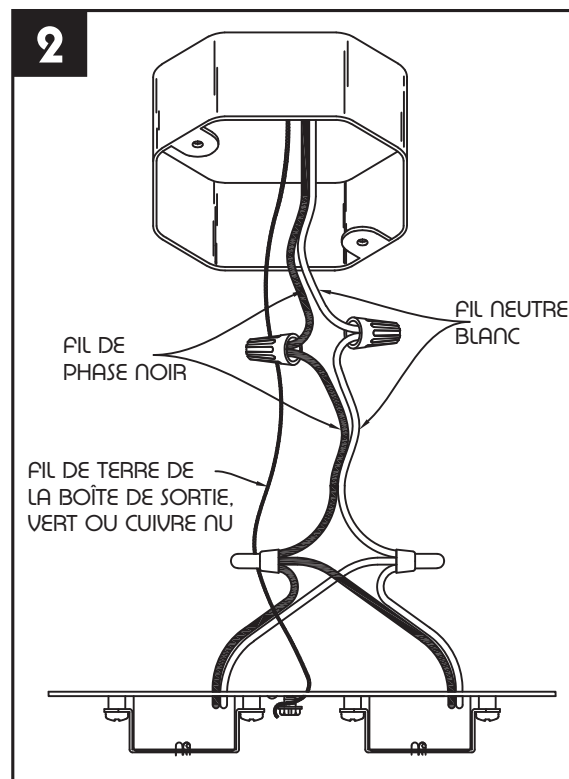

3. Orientez le support de fixation (B) de sorte que les bras soient dirigés à l'opposé de la boîte de sortie (non fournie). Fixez le support de fixation (B) à la boîte de sortie à l'aide des vis à métaux courtes (BB).

### Quincaillerie utilisée

**BB** Vis à métaux courtes

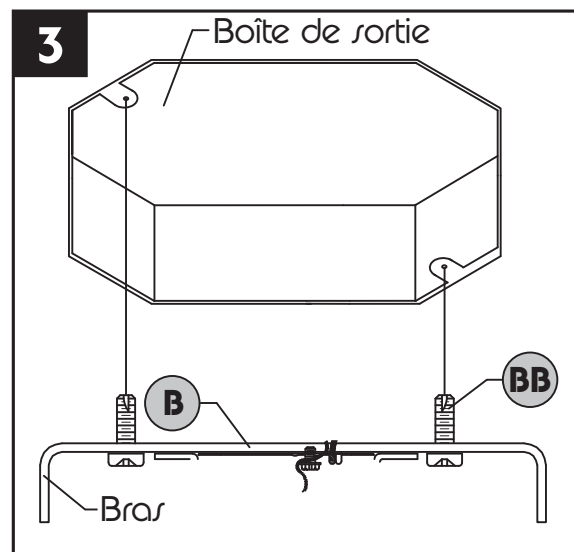

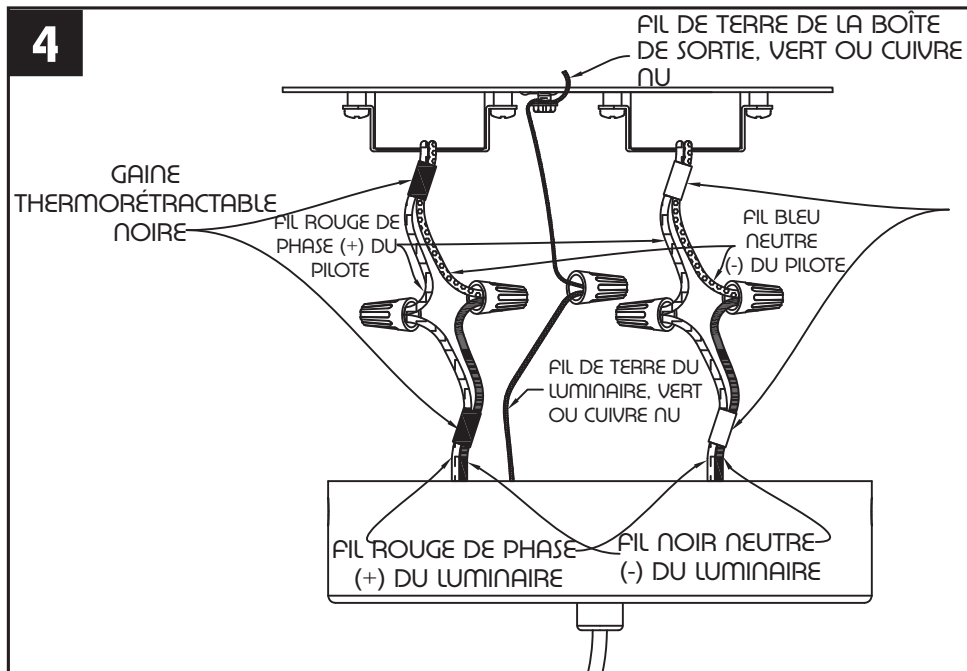

#### 4. Guide de raccordement électrique (du luminaire au pilote) :

Fil de mise à la terre : connectez le fil de terre du luminaire à celui de la boîte de sortie, préalablement attaché à la vis de terre du support de fixation.

Fils d'alimentation : **\*\*REMARQUE** : connectez une paire de fils du luminaire à chaque pilote. Les « paires » de fils sont regroupées par des gaines thermorétractables.

- Connectez le fil Neutre (Bleu) de sortie du pilote au fil Neutre (Noir) du luminaire.
- Connectez le fil de Phase (Rouge) de sortie du pilote au fil de Phase (Rouge) du

#### 5. Placez le pavillon (A) sur les bras sortant du support de fixation (B) et fixez-le à l'aide des rondelles (DD) et vis du pavillon (CC).

#### Quincaillerie utilisée

- CC** Vis du pavillon  x 2

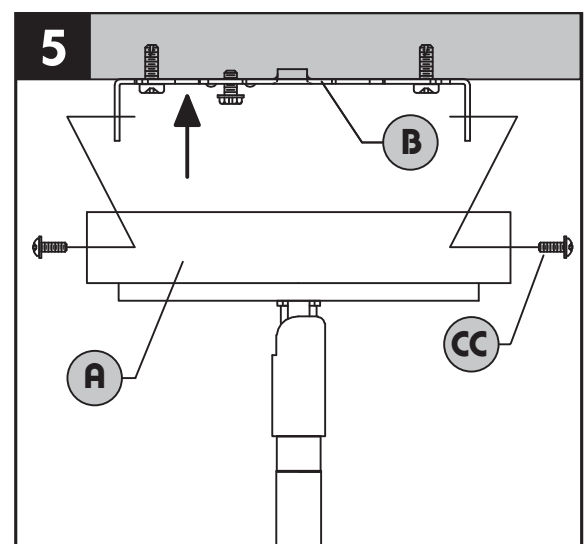

## ENTRETIEN

- Vérifiez toujours que le courant est coupé avant de nettoyer le luminaire.
- Les abat-jour en verre peuvent être nettoyés dans un évier couvert de serviettes, à l'aide d'eau tiède et de savon doux. Ne nettoyez pas les abat-jour dans un lave-vaisselle.

## DÉPANNAGE

| PROBLÈME                      | CAUSE POSSIBLE                   | MESURE CORRECTIVE                             |
|-------------------------------|----------------------------------|---|
| Le luminaire ne s'allume pas. | 1. Le luminaire est mal branché. | 1. Vérifiez si le luminaire est bien branché. |

## LIMITED WARRANTY ON KICHLER® ÉLAN BRAND LIGHT FIXTURES

Kichler Lighting LLC warrants its light fixtures to the original consumer purchaser to be free from defects in material and workmanship for the applicable period specified below:

Kichler® élan Light Fixtures

One (1) year from the date of purchase by the original consumer purchaser.

Kichler® élan Light Fixtures with LED Light Engines and Electrical Components

three (3) years from the date of purchase by the original consumer purchaser on the Light Engine and all other electrical components.

What We Will Do

Kichler Lighting LLC will repair or replace, free of charge, during the applicable warranty period (as described above), any light fixture that proves defective in material and/or workmanship under normal installation, use and service. If repair or replacement is not practical, Kichler Lighting LLC may elect to refund the purchase price in exchange for the return of the product. These are your exclusive remedies.

What Is Not Covered

Polished brass product finishes and non-LED light bulbs carry no warranty. Any labor charges incurred by the original consumer purchaser to repair or replace this product are not covered by this warranty. Kichler Lighting LLC shall not be liable for any damage to the product resulting from reasonable wear and tear, voltage overload, outdoor use (where the annual average ambient temperature is below 27° or above 95° Fahrenheit), misuse (including use of the product for an unintended application), abuse, neglect or improper or incorrectly performed installation, maintenance or repair, including failure to follow the applicable care and cleaning instructions. Kichler Lighting LLC recommends using a professional electrician for all installation and repair of light fixtures. We also recommend that you use only genuine Kichler® replacement parts.

What You Must Do to Obtain Warranty Service or Replacement Parts

A warranty claim may be made, and replacement parts may be obtained by contacting the distributor from whom you purchased the light fixture. If the distributor is not available, please call 866-558-5706 or contact us by mail as follows (please include your model number and date of purchase):



## **GARANTIE (suite)**

Kichler Lighting LLC  
7711 East Pleasant Valley Rd  
Cleveland, OH 44161-8010

Proof of purchase (original sales receipt) from the original purchaser must be made available to Kichler Lighting LLC for all warranty claims.

### *Limitation on Duration of Implied Warranties*

TO THE EXTENT PERMITTED BY LAW, ANY IMPLIED WARRANTY, INCLUDING THE IMPLIED WARRANTIES OF MERCHANTABILITY AND OF FITNESS FOR A PARTICULAR PURPOSE, IS LIMITED TO THE STATUTORY PERIOD OR THE DURATION OF THIS WARRANTY, WHICHEVER IS SHORTER. Some states/provinces do not allow limitations on how long an implied warranty lasts, so the above limitation may not apply to you.

### *Limitation of Special, Incidental or Consequential Damages*

KICHLER LIGHTING LLC SHALL NOT BE LIABLE FOR ANY SPECIAL, INCIDENTAL OR CONSEQUENTIAL DAMAGES (INCLUDING LABOR CHARGES TO REPAIR, REPLACE, INSTALL OR REMOVE THIS PRODUCT), WHETHER ARISING OUT OF BREACH OF ANY EXPRESS OR IMPLIED WARRANTY, BREACH OF CONTRACT, TORT, OR OTHERWISE. KICHLER LIGHTING LLC SHALL NOT BE LIABLE FOR ANY DAMAGE TO THE PRODUCT RESULTING FROM REASONABLE WEAR AND TEAR, OVERLOAD, OUTDOOR USE (WHERE THE ANNUAL AMBIENT TEMPERATURE IS BELOW 27° OR ABOVE 95° FAHRENHEIT), MISUSE (INCLUDING USE OF THE PRODUCT FOR AN UNINTENDED APPLICATION), ABUSE, NEGLIGENCE OR IMPROPER OR INCORRECTLY PERFORMED INSTALLATION, MAINTENANCE OR REPAIR, INCLUDING FAILURE TO FOLLOW THE APPLICABLE INSTALLATION, CARE AND CLEANING INSTRUCTIONS. Some states/provinces do not allow the exclusion or limitation of special, incidental or consequential damages, so the above limitations and exclusions may not apply to you. Notice to residents of the State of New Jersey: The provisions of this warranty, including its limitations, are intended to apply to the fullest extent permitted by the laws of the State of New Jersey.

### *Additional Rights*

This warranty gives you specific legal rights, and you may also have other rights which vary from state/province to state/province.

This is Kichler Lighting LLC's exclusive written warranty and the warranty is not transferable.

## LISTE DES PIÈCES DE RECHANGE

Pour obtenir des pièces de rechange, appelez notre service à la clientèle au **1 866 558-5706**, entre 8 h et 16 h (HNE), du lundi au vendredi.

| PIÈCE | DESCRIPTION            | N° DE PIÈCE |
|-------|------------------------|-------------|
| E     | Tube fileté de 15,2 cm | PIPEX06-MBK |
| F     | Tube fileté de 30,5 cm | PIPEX12-MBK |
| AA    | Capuchon de connexion  | WC001       |
| BB    | Vir à métaux courte    | SCR832X050  |
| CC    | Vir du pavillon        | CS84087     |

