

Item P/N	Description	A	B	C	D	Color Code Suffix		
X-22-1171	W- Bracket +2"	7.440	4.000"	6.000"	1.025"	()	(BL)	(BR)
X-22-1181	W- Bracket +4"	9.440	4.000"	6.000"	1.025"	()	(BL)	(BR)
X-22-1191	W- Bracket +6"	11.440	4.000"	6.000"	1.025"	()	(BL)	(BR)

- () Silver
- (BL) Black
- (BR) Bronze

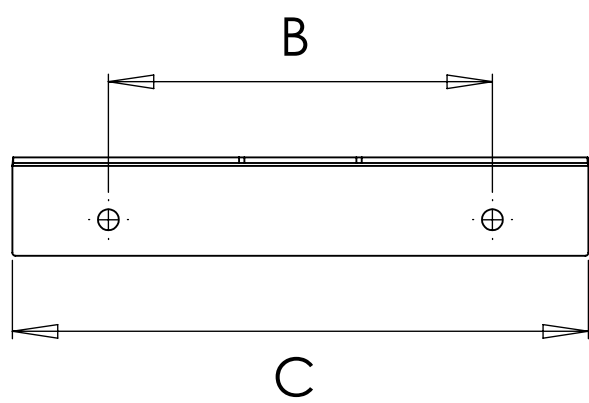
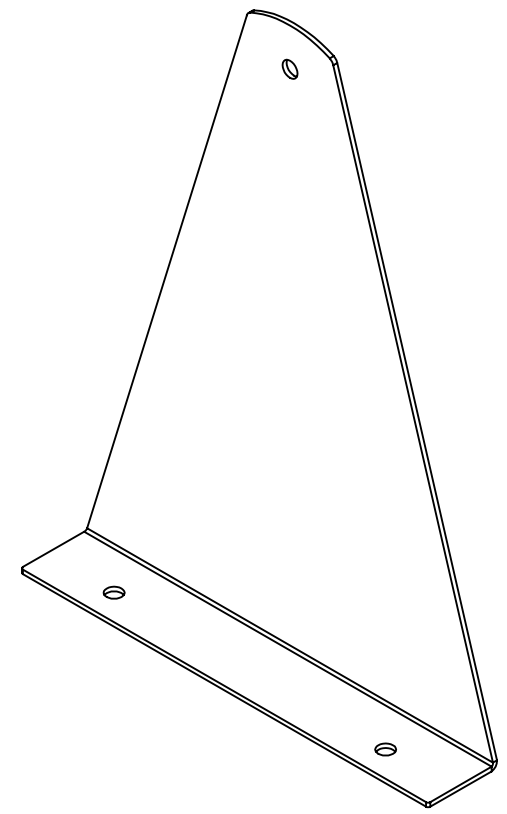
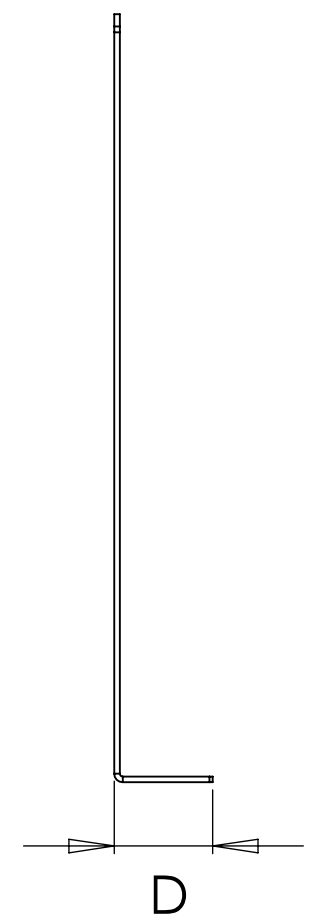
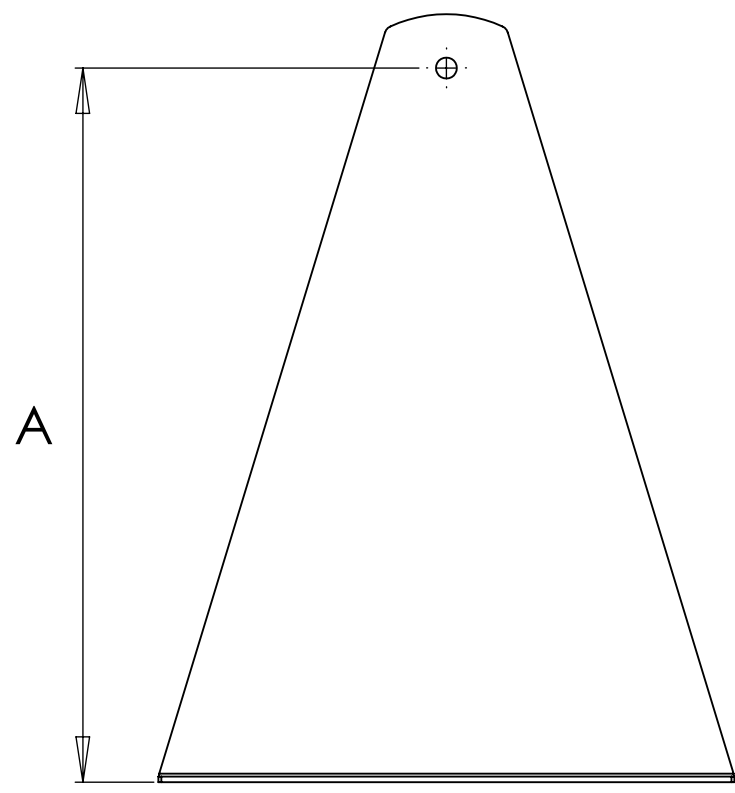

PROPRIETARY AND CONFIDENTIAL
 THE INFORMATION CONTAINED IN THIS DRAWING IS THE SOLE PROPERTY OF INFRATECH. ANY REPRODUCTION IN PART OR AS A WHOLE WITHOUT THE WRITTEN PERMISSION OF INFRATECH IS PROHIBITED.

		UNLESS OTHERWISE SPECIFIED:		NAME	DATE	INFRATECH	
		DIMENSIONS ARE IN INCHES		DRAWN	O.A.		8-112018
		TOLERANCES:		CHECKED			
		FRACTIONAL ±		ENG APPR.			
		ANGULAR: MACH ± BEND ±		MFG APPR.			
		TWO PLACE DECIMAL ±		Q.A.			
		THREE PLACE DECIMAL ±		COMMENTS:			
		INTERPRET GEOMETRIC TOLERANCING PER:					
		MATERIAL				SIZE	
		16ga 304 SS				DWG. NO.	
		FINISH				REV	
		TBD					
NEXT ASSY	USED ON	DO NOT SCALE DRAWING				SCALE: N/A	
APPLICATION						WEIGHT:	
						SHEET 1 OF 1	

