

PREPARING FOR INSTALLATION

Carefully remove all contents from the carton. Shut off the power at the circuit breaker and completely remove the old fixture from the wall, including the old mounting bracket. Remove the new mounting bracket assembly from the bag. Then remove cap nuts (F) from mounting screws (C). Place the mounting plate (A) over the junction box so that mounting screws (C) and nuts (H) extend out away from the wall. Depending on the placement of your junction box the position of mounting screws (C) may need to be adjusted to allow the backplate to be flush with the wall. Adjust the position of mounting screws (C) so that mounting screws (C) can be exposed 5-6 mm after passing through the backplate (E) to properly fit the cap nuts. Mounting screws (C) can be adjusted by loosening nuts (H) and loosening or tightening mounting screws (C). Once the ideal position of mounting screws (C) has been confirmed, tighten nuts (H) on mounting screws (C) on the front of the mounting plate to ensure that mounting screws (C) are secure. Pull the house wires through the center of mounting plate (A). Secure mounting plate (A) to the junction box by tightening the screws (B).

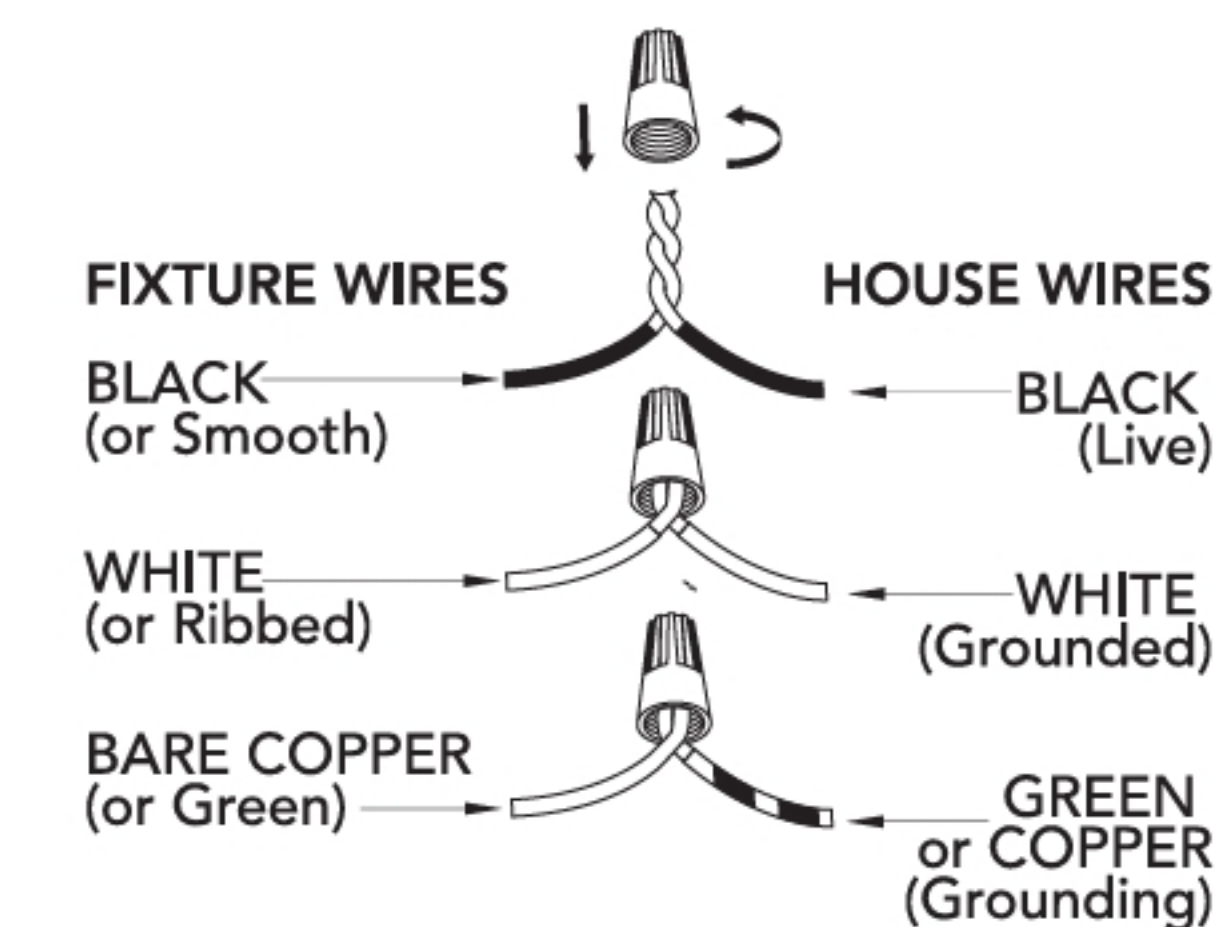

CONNECTING THE WIRES

Have a helper support the fixture's weight while completing the wiring. Attach the fixture's wires to the power supply wires from the junction box. Connect black to black (Live); white to white (grounded); grounding to grounding (green or copper). Twist the ends of the wire pairs together. Then, twist on a wire connector. Make sure all twists are in the same direction. Loop fixture's ground wire around grounding screw (D) and tighten. If there is no ground wire (green or copper) from the junction box, contact a qualified electrician.

FINISHING THE INSTALLATION

Place the fixture's backplate (E) over the mounting screws (C) so the threads protrude through the holes on the front of the backplate. Tightly screw the cap nuts (F) onto the mounting screws (C) until the backplate (E) of the fixture is snugly against the wall. Install light bulb (not included) in accordance with the fixture's specifications. Do not exceed the recommended wattage. Your installation is now completed. Turn on the power and test the fixture.

CLEANING TIPS

Treat the fixture gently! Regular cleaning will reduce the need for deep cleaning. For regular cleaning, turn off the light and wipe down the fixture with a clean lint-free cotton or microfiber cloth. Never spray cleaner directly onto the fixture.

Hunter

Gablecrest

For Models:
Para los Modelos:
Pour les Modèles:
19375
19376

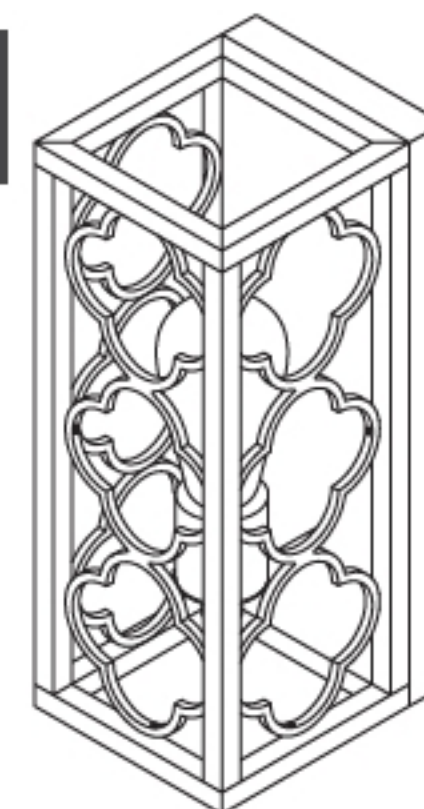

Here are the tools you'll need to complete your installation:
Estas son las herramientas que usted necesitará para completar su instalación:
Voici les outils dont vous aurez besoin pour réaliser l'installation:

Hardware Service Kit/Kit De Mantenimiento Del Equipo/Trousse De Maintenance Quincaillerie

- 1 Light Wall Sconce
- 1 Luz Candelabro de Pared
- 1 Lumière Applique Murale

Fixture weight ±2 lbs:
Peso ±2 lb: 4.5 lbs (2.04 kg)
Poids fixe ±2 lbs:

Hardware Service Kit/Kit De Mantenimiento Del Equipo/Trousse De Maintenance Quincaillerie

Part #/Pieza #/Pièce #	Model/Modelo/Modèle	Finish/Finish/Fin
KD81501L08	19375	Rustic Iron/Hierro Rústico/Fer Rustique
KD81501L16	19376	Distressed White/Blanco Envejecido/Blanc Patiné



Ladder
Escalera
Échelle

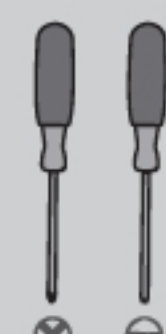

Screwdriver
Destornilladore
Tournevis



Pliers
Alicates
Pince

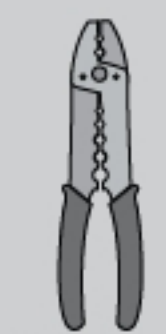

Wire Strippers
Pelacables
Pince à dénuder

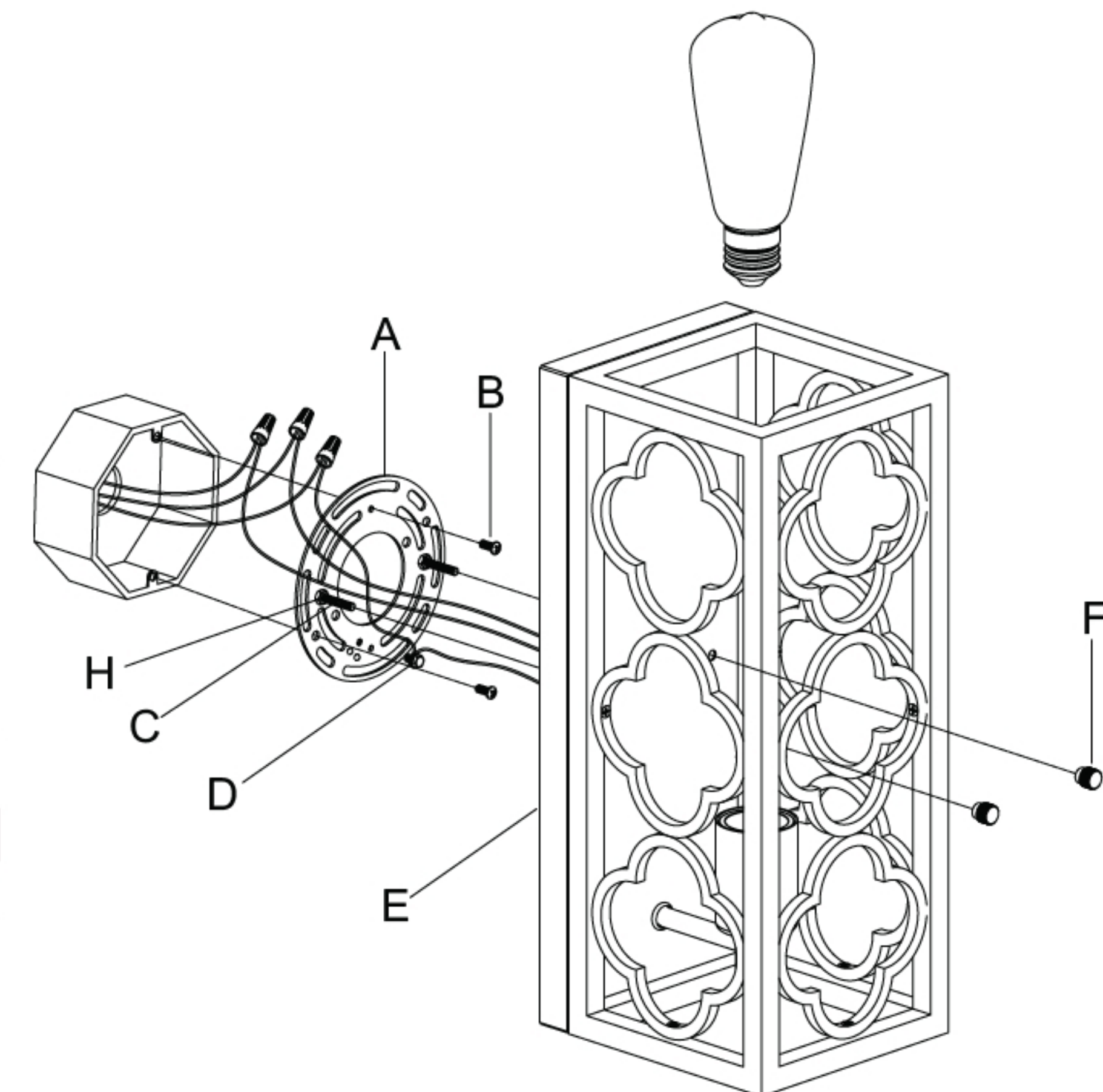

INSTALLATION INSTRUCTIONS INSTRUCCIONES DE INSTALACIÓN/ INSTRUCTIONS D'INSTALLATION

⚠ WARNING

- To avoid possible electrical shock, before installing your light fixture, disconnect the power by turning off the circuit breakers to the outlet box associated with the wall switch location.
- The lighting fixture must be grounded. If the ground wire for the installation site is not present, immediately STOP installation and consult a qualified electrician.
- All wiring must be in accordance with national and local electrical codes ANSI/NFPA 70. If you are unfamiliar with wiring or in doubt, consult a qualified electrician.

READ AND SAVE THESE INSTRUCTIONS
These instructions are provided for your safety. It is very important that they are read carefully and completely before beginning installation of the lighting fixture.

⚠ ADVERTENCIA

- Para evitar una posible descarga eléctrica, antes de instalar su lámpara, desconecte la energía apagando los interruptores automáticos (breakers) que alimentan la caja de salida asociada con la ubicación del interruptor de pared.
- L'appareil d'éclairage doit être mis à la terre. Si le fil de terre du lieu d'installation n'est pas présent, ARRÊTEZ immédiatement l'installation et consultez un électricien qualifié.
- Todo el cableado debe realizarse de acuerdo con los códigos eléctricos locales y nacionales ANSI/NFPA 70. Si no está familiarizado con el cableado, o si tiene duda, consulte a un electricista calificado.

LEA Y GUARDE ESTAS INSTRUCCIONES
Estas instrucciones se proporcionan para su seguridad. Es muy importante leerlas detenidamente y completamente antes de comenzar la instalación de la lámpara.

⚠ AVERTISSEMENT

- Pour éviter tout choc électrique, avant d'installer le luminaire, coupez le courant en éteignant les disjoncteurs de la boîte électrique associée à l'interrupteur mural.
- Le luminaire doit être mis à la terre. Si le fil de terre du lieu d'installation n'est pas présent, ARRÊTEZ immédiatement l'installation et consultez un électricien qualifié.
- Tout le câblage doit être conforme aux codes électriques nationaux et locaux en vigueur et à la norme ANSI/NFPA 70. Si vous n'avez pas l'habitude de faire ce câblage ou en cas de doute, adressez-vous à un électricien qualifié.

LISEZ ET CONSERVEZ CES INSTRUCTIONS
Ces instructions sont fournies pour votre sécurité. Il est très important de les lire attentivement dans leur intégralité avant d'entreprendre l'installation du luminaire.