

# Assembly & Installation Instructions



For Post-Mounted 34-4820 & 34-4820F

Page 1 of 3

**CAUTION: FAILURE TO INSTALL THIS FIXTURE PROPERLY MAY RESULT IN SERIOUS PERSONAL INJURY OR DEATH AND PROPERTY DAMAGE. We recommend installation by a licensed electrician.**

This product must be installed in accordance with applicable installation code(s), by a person familiar with the construction and operation of the product and the hazards involved.\*

**Caution:** Do not exceed maximum wattage noted on fixture. Use only recommended bulbs with fixture.

**Note:** Fixture, Post and Cover Cap each sold separately.

## **To Install** (Figure 1)

### Component Parts

A	J Bolt	E	Hex Nut (4)
B	Post	F	Cover Cap
C	Flat Washer (4)	G	Set Screw
D	Split Washer (4)	H	Fixture

**Caution:** Be sure power is off at the main breaker box prior to installation.

### **Site Preparation**

1. Run appropriate wiring to the site of the fixture, leaving enough excess wire to reach the top of the post, plus 12 inches.
2. Pour flat and level concrete base with wiring emerging at the center. Insert J bolts (A) so approximately 1" of the bolts are exposed above the concrete. Position J bolts according to the template on the last page of these instructions. Allow concrete to cure before installing fixture.

### **Installation**

**Note:** Post may be cut to desired height before installation.

1. Position post over J bolts allowing supply wire to run up though the post and secure using flat washers (C), split washers (D) and hex nuts (E).
2. Place optional cover cap (sold separately) (F) over post to conceal mounting hardware.
3. Connect fixture wires to supply wires using appropriate wire connectors (not provided), black to black, white to white and bare copper or green to bare copper or green. If fixture is wired with twin lead lamp cord, connect smooth side of fixture wire to black, and ridged side to white.
4. Place fixture (H) onto post carefully tucking all wiring down into post and making sure no wires are pinched between the post and the fixture. Secure with set screw (G).

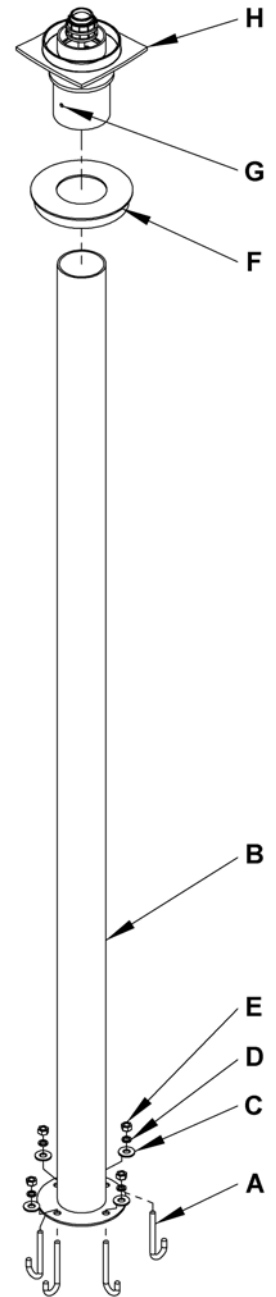

(Figure 1)

(continued)

# Assembly & Installation Instructions



For Post-Mounted 34-4820 & 34-4820F

Page 2 of 3

## To Install Glass (Figure 2)

### Component Parts

- I Inner Glass
- J Outer Glass
- K Glass Cage
- L Retaining Ring (2)
- N Socket

1. Remove retaining rings (L) from socket (N). *Retaining Rings are shipped installed.*
2. Slip outer glass (J) over socket (N).
3. Slip glass cage (K) over socket (N).
4. Thread first retaining ring (L) onto socket until it rests on bottom of outer glass (J). Thread second retaining ring onto socket until it is snug against first retaining ring. *Do not over tighten.*
5. Install bulb. *(Fluorescent versions bulb is included.)*
6. Slip inner glass (I) over socket (N) and bulb.

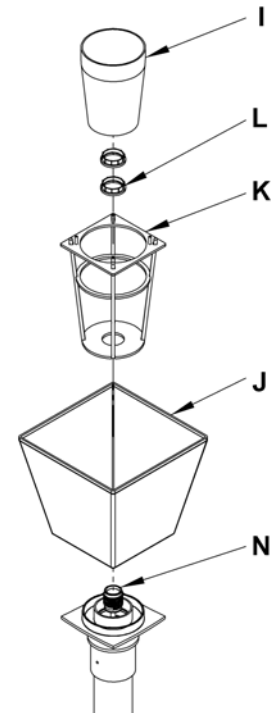

(Figure 2)

## To Install Top Hat (Figures 3 & 4)

### Component Parts

- J Outer Glass
- K Glass Cage
- M O-Ring (2)
- O Top Hat
- P Threaded Stud
- Q Flat Head Screw (4)
- R Top Cover
- S Finial
- T Cover Plate

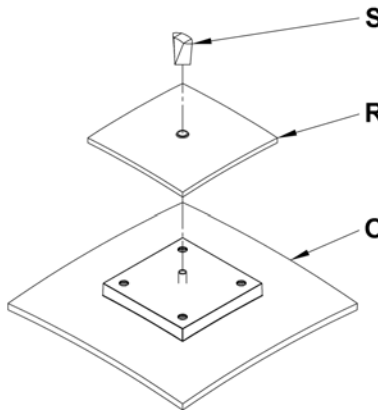

(Figure 3)

1. Disassemble upper assembly by unthreading finial (S) (Figure 3).
2. Install cover plate (T) aligning the four holes with the four standoffs so it rests on top of glass cage (K).
3. Place top hat (O) on top edge of outer glass (J) and align holes in top hat (O) with standoffs in glass cage (K).
4. Install four flat head screws (Q) and tighten.
5. Slip top cover (R) over threaded stud and let rest on the top hat (O).
6. Slip two o-rings (M) onto threaded stud (P).
7. Thread finial (S) onto threaded stud (P) until snug against top cover (R). *Align as shown if figure 3.*
8. Restore electricity at main breaker.

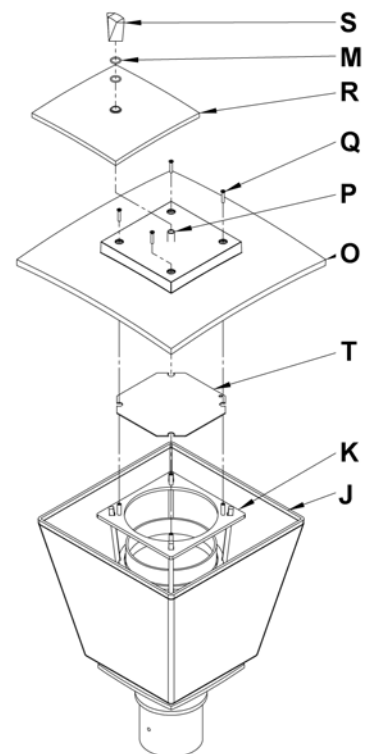

(Figure 4)

(continued)

# Assembly & Installation Instructions



For Post-Mounted 34-4820 & 34-4820F

Page 3 of 3

Use this template to position J bolts and wireway in concrete slab prior to installing outdoor post mounted lighting fixture.

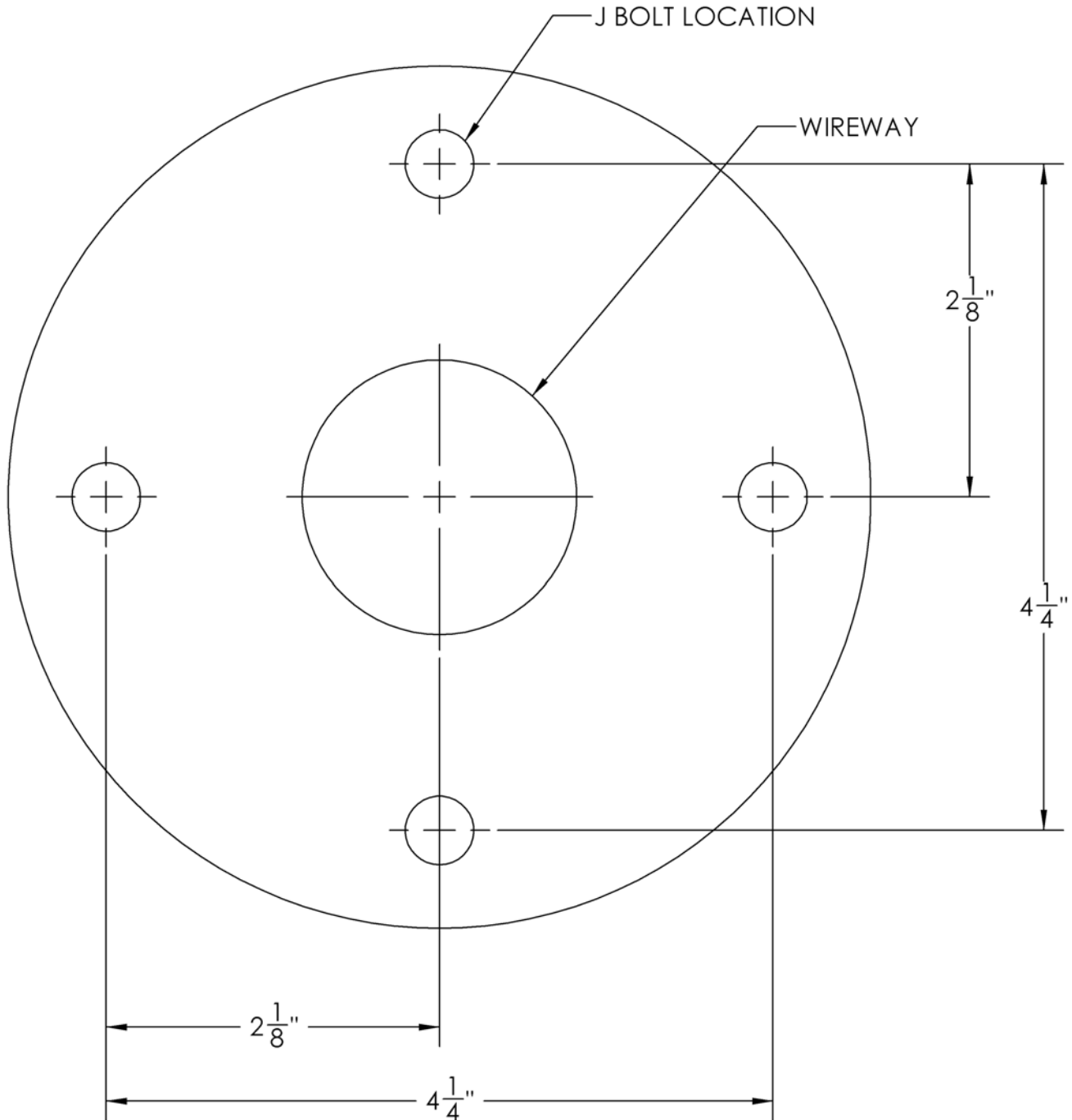

*If you need further assistance, or find that you are missing any parts, please contact the dealer from which you purchased this product. We hope you enjoy your fixture!*

\* Hubbardton Forge will not be liable for injury or damage caused by improper installation, lamping or use of this fixture.