

# Assembly & Installation Instructions

For Direct Wire Wall-Mounted Sconces 30-4210, 30-4215 & 30-4220

**B115**

Page 1 of 2

**CAUTION: FAILURE TO INSTALL THIS FIXTURE PROPERLY MAY RESULT IN SERIOUS PERSONAL INJURY OR DEATH AND PROPERTY DAMAGE. We recommend installation by a licensed electrician.**

This product must be installed in accordance with applicable installation code(s), by a person familiar with the construction and operation of the product and the hazards involved.\*

**Caution:** Do not exceed maximum wattage noted on fixture. Use only recommended bulbs with fixture.

## To Install Fixture (Figures 1 & 2)

### Component Parts

- |   |                   |   |              |
|---|-------------------|---|--------------|
| A | Crossbar          | E | Fixture      |
| B | Ground Screw      | F | Caulking Lip |
| C | Threaded Stud (2) |   |              |
| D | Knurl Balls (2)   |   |              |

**Caution: Be sure power is off at the main breaker box prior to installation.**

1. Carefully unpack fixture from carton.
2. Using two machine screws (not provided), fasten the crossbar (A) to the outlet box, making sure the mounting holes are level.

**Note:** A new outlet box comes with screws. When replacing a fixture, retain the screws for use with the new fixture.

3. Start threaded studs (C) into appropriate holes in crossbar.
4. Move fixture (E) into position. Using suitable wire connectors (not provided), connect the fixture wires to the supply wires; white to white, black to black, and bare copper or green to bare copper or green. Connect all ground wires to crossbar ground screw (B).

**Caution:** Make sure wire connectors are twisted on securely and no bare wires are exposed.

5. Apply a generous bead of a suitable caulking material to caulking lip (F) on the fixture.
6. Carefully tuck all wires behind the fixture. Place fixture (E) over threaded studs and tighten firmly to mounting surface using knurl balls (D).
7. Restore electricity at the main breaker.
8. Install glass per instructions on next page.

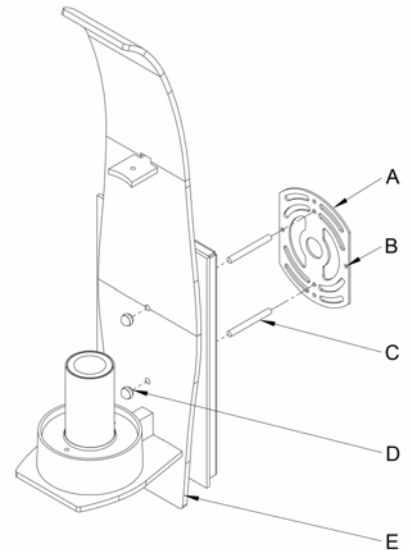

(Figure 1)

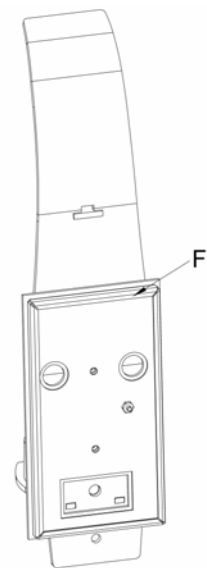

(Figure 2)

# Assembly & Installation Instructions

For Direct Wire Wall-Mounted Sconces 30-4210, 30-4215 & 30-4220

**B115**

Page 2 of 2

## To Install Glass (Figure 3)

### Component Parts

- E** Fixture
- G** Thumb Screw
- H** Glass Ring
- I** Glass

1. Remove glass ring (H) from fixture (E) by removing thumb screw (G). *Glass rings are shipped installed.*
2. Install light bulb (not provided).
3. Slip glass ring (H) over glass (I). Install glass (I) aligning glass ring (H) hole with threaded hole in fixture (E). (Figure 3)
4. Install thumb screw (G) to attach glass ring (F) to fixture (C).
5. Restore electricity at the main breaker.

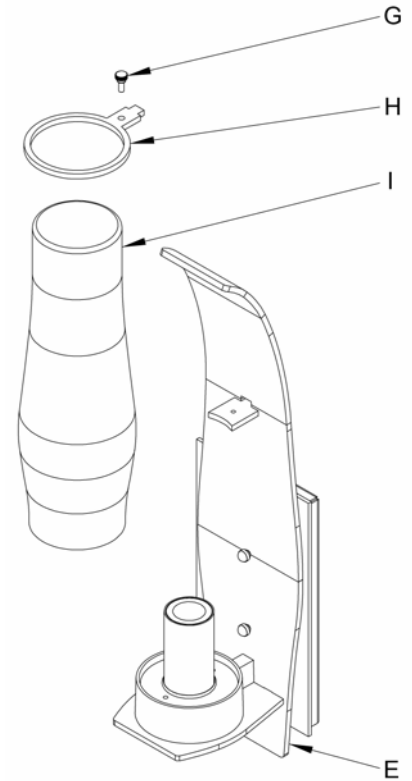

(Figure 3)

*If you need further assistance, or find that you are missing any parts, please contact the dealer from which you purchased this product. We hope you enjoy your fixture!*

\* Hubbardton Forge will not be liable for injury or damage caused by improper installation, lamping or use of this fixture.