

Glass Installation & Front Mounting Instructions

Gallery Sconce Model 21-7640

B58

Page 1 of 2

To Install Front Glass

Component Parts

- A Fixture Front Panel
- B Threaded Stud
- C Glass
- D Washer
- E Hex Nut
- F Glass Stop

1. Remove hex nut (E) and washer (D) from fixture front panel (A) and save for later use.
2. Insert glass (C) into fixture front panel (A).
3. Slide the glass into glass stop (F) at bottom of fixture inside the panel.
4. Secure glass in position by placing washer (D) and hex nut (E) onto threaded stud (B).
Be careful not to over tighten hex nut causing glass to break.

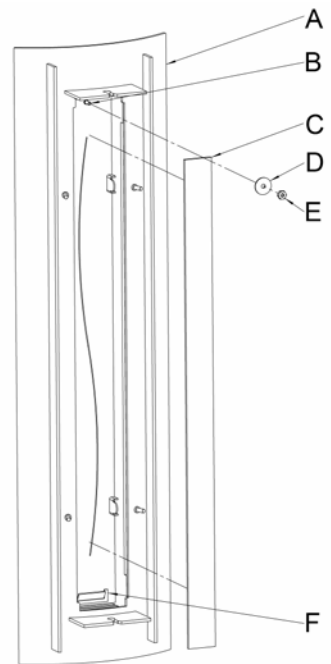

(Figure 1)

To Install Side Diffuser Glass

Component Parts

- C Glass (2)
- G Glass Rest
- H Threaded Stud
- I Glass Clip (4)
- J Knurled Ball (4)

1. Install glass (C) in to glass rest (G).
2. Install glass clips (I) and knurl ball (J).
3. Slide glass clip (I) against glass (C) and tighten knurl ball (J). Be careful not to over tighten knurl ball causing glass to break.

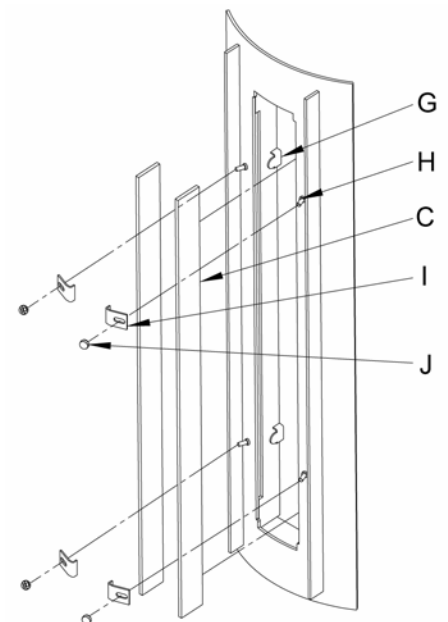

(Figure 2)

(continued)

Glass Installation & Front Mounting Instructions

Gallery Sconce Model 21-7640

Page 2 of 2

To Install Front Panel

Component Parts

- A Fixture Front Panel
- K Ball Head Screw (2)
- L Fixture Can Assembly

1. Install light bulb (Fluorescent or G9).
Caution: Do not touch G9 bulbs with bare hands; oil from hands will reduce bulb life.
2. Thread ball head screw (K) in top and bottom of fixture can assembly (L). Only thread a couple of turns for each screw.
3. Align slots on the top and bottom of fixture front panel (A) with the ball head screws previously installed into fixture can assembly (L). Slide the fixture front panel (A) back until it bottoms out on fixture can assembly (L).
4. Tighten both ball head screws (K) to secure fixture front panel (A).

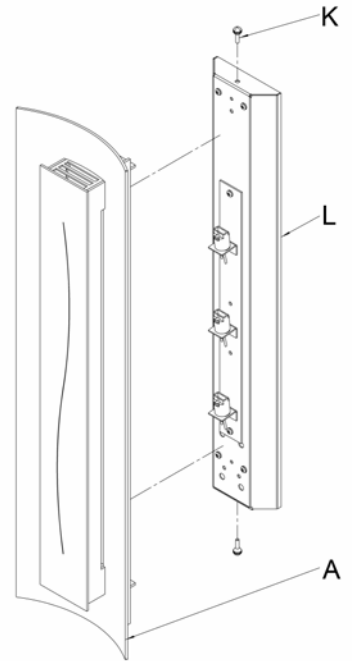

(Figure 3)

If you need further assistance, or find that you are missing any parts, please contact the dealer from which you purchased this product. We hope you enjoy your fixture!