

# Installation Instructions

For Axis Semi-Flush 12-6401

**A232**

Page 1 of 2

**CAUTION: FAILURE TO INSTALL THIS FIXTURE PROPERLY MAY RESULT IN SERIOUS PERSONAL INJURY OR DEATH AND PROPERTY DAMAGE. We recommend installation by a licensed electrician.**

This product must be installed in accordance with applicable installation code(s), by a person familiar with the construction and operation of the product and the hazards involved.\*

**Caution:** Do not exceed maximum wattage noted on fixture. Use only recommended bulbs with fixture.

## Prepare to Install Fixture (Figure 1)

### Component Parts

- A Canopy
- B Lower Assembly
- C Screw Cap

1. Carefully unpack the fixture from the carton.
2. Remove screw cap (C) from canopy (A).
3. Remove lower assembly (B) from canopy (A). Save all parts for later use.

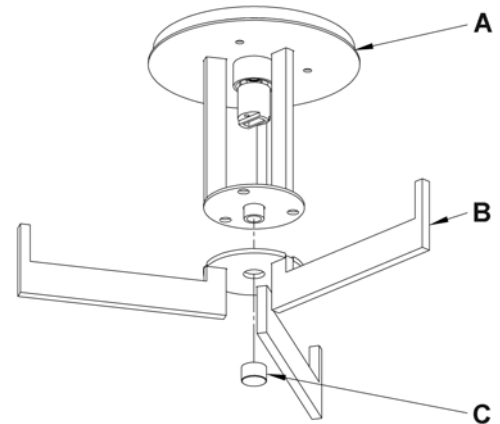

(Figure 1)

## To Install Fixture (Figure 2)

### Component Parts

- A Canopy
- D Cross Bar
- E Threaded Stud (3)
- F Barrel Knobs (3)
- G Ground Screw

**Caution: Be sure power is off at the main breaker box prior to installation**

1. Thread studs (E) through appropriate holes in cross bar (D) to match hole centers in canopy (A). Move ground screw (G) to another available threaded hole if necessary.
2. Using two machine screws (not provided) fasten cross bar (D) to the electric box using outer oval holes to orient fixture to desired hanging position.  
**Note:** A new electric box comes with screws. When replacing an existing fixture, retain the screws for use with the new fixture.
3. Using suitable wire connectors (not provided); connect fixture wires to supply wires (white to white and black to black). Connect all ground wires to green ground screw (G).  
**Caution:** Make sure wire connectors are twisted on securely, and no bare wire is exposed.
4. Slide fixture canopy (A) over threaded studs and push firmly to ceiling, making sure that no wires are pinched between fixture canopy and ceiling. Fasten with barrel knobs (F). Be sure studs (E) are fully seated in barrel knobs (F).

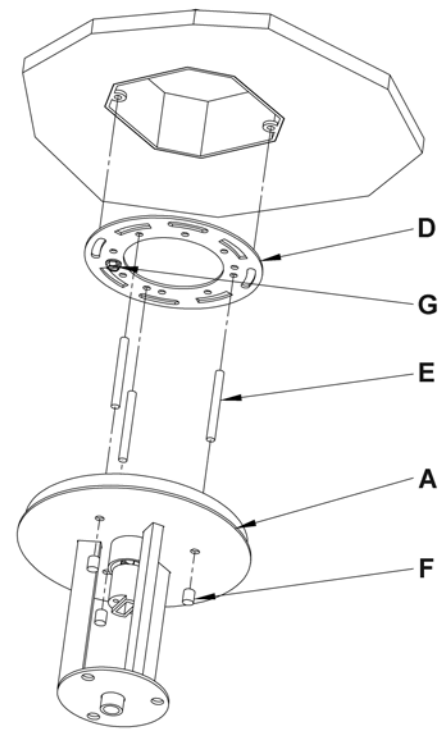

(Figure 2)

# Installation Instructions

For Axis Semi-Flush 12-6401

**A232**

Page 2 of 2

## To Complete Assembly (Figures 3 & 4)

### Component Parts

- A Canopy
- B Lower Assembly
- C Screw Cap
- H Outer Glass
- I Inner Glass
- J Diffuser
- K Bulb (included)
- L Threaded Stud
- M Locating Pin

1. Install diffuser (J) on lower assembly (B) so it rests on the three legs.
2. Install inner glass (I) and outer glass (H) onto lower assembly (B).
3. Install light bulb (K). *Be careful not to touch bulb with bare hands; oil from the hands will dramatically reduce bulb life.*
4. Raise lower assembly (B) with glass installed aligning locating pin aligns with one of the three holes in the canopy (A).
5. Install screw cap (C) and tighten.
6. Restore electricity at main breaker.

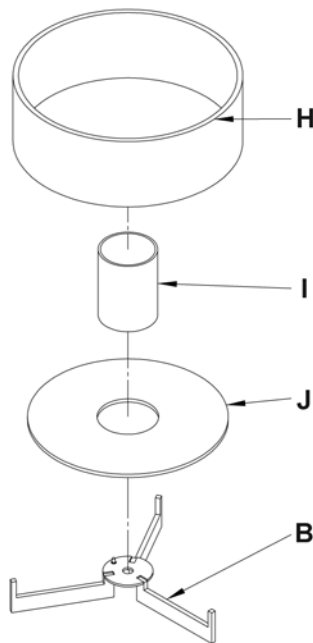

(Figure 3)

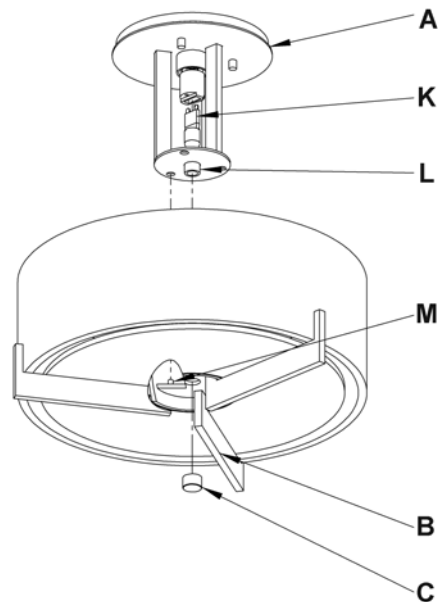

(Figure 4)

*If you need further assistance, or find that you are missing any parts, please contact the dealer from which you purchased this product. We hope you enjoy your fixture!*

\* Hubbardton Forge will not be liable for injury or damage caused by improper installation, lamping or use of this fixture.