

INSTALLATION INSTRUCTIONS FOR P5217-L

For LED Wall Mount Fixture

WARNING! SHUT POWER OFF AT FUSE OR CIRCUIT BREAKER.
AVERTISSEMENT ! COUPER LE COURANT AU NIVEAU DES FUSIBLES OU DODISJONCTEUR.

PREPARATION

1. Shut off power at the fuse box or circuit breaker box. If necessary remove the old fixture and mounting hardware.
2. Carefully unpack your new fixture and lay out all the parts on a clear area. Take care not to lose any small parts necessary for installation.
3. Position mounting plate (B) on the wall, and mark the location of the two drywall anchors (A). Pre-drill the holes for the drywall anchors (A). Insert the drywall anchors (A) into the wall.
4. Attach the mounting plate (B) to the junction box with mounting screws (E) (Size: 8-32*1/2"L) and wood screws (D). The side of the mounting plate marked "GND" must face out.

CONNECTING THE WIRES

5. Connect the electrical wires as shown in Fig.2, making sure that all wire nuts are secured. If your outlet has a ground wire (green or bare copper), connect the fixture's ground wire to it. Otherwise, connect the fixture's ground wire directly to the Mounting plate (B) using the green screw (P) provided. Tuck the wire connections neatly into the junction box.

FINISHING THE INSTALLATION (FIG. 1)

6. Align fixture (F) to screws (C) and secure with cap nuts (O).
7. Align screw (I), steel gasket (J) and plastic gasket (K) to the glass (N) and secure into hook (L).
8. Align hook (L) with glass (N) to fixture (F) and secure with screws (M).

CAUTION /ATTENTION: When handling the fixture, do not apply pressure to the LEDs. Hold the fixture by the base or back plate (F) only.

Replacing LED module (Fig. 3)

The LED module can be replaced by a qualified electrician without cutting of wire and without damage to any decorative element to which the fixture is attached. See installation steps for more details (Fig. 3)

Warning: Turn off power at the circuit breaker before replacing LED module or LED driver.

- a. Remove screws (M) to remove glass (N) from the fixture (F).
- b. Remove ball nuts (O) to remove the fixture (F) from the mounting plate (B).
- c. Remove the wire nuts located inside the junction box.
- d. Remove screws (Q) to remove the bracket (P) from the fixture (F). Remove the wire nuts located inside the bracket (P), remove screw (T) on fastener (U) to disconnect the LED module.
- e. Remove screws (S) and plastic gasket (V) and carefully remove the LED module (R) from bracket (P),
- f. Reverse steps a-c for installing the new LED module.
- g. Note: The LED module should be provided by a specified supplier.
- h. For better heat dissipation the LED module should be applied with thermal grease when re-lamping.

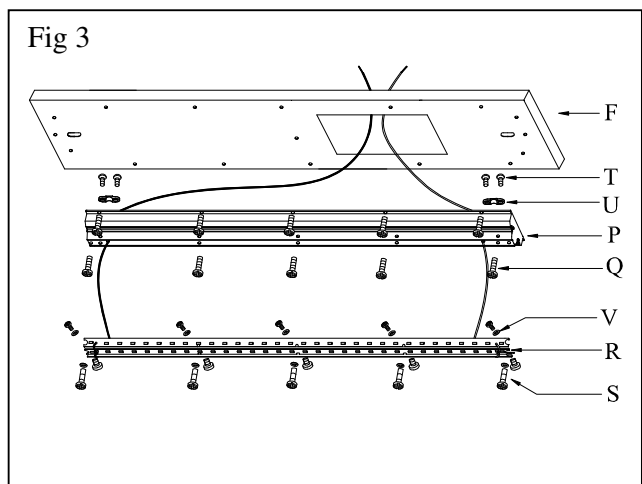
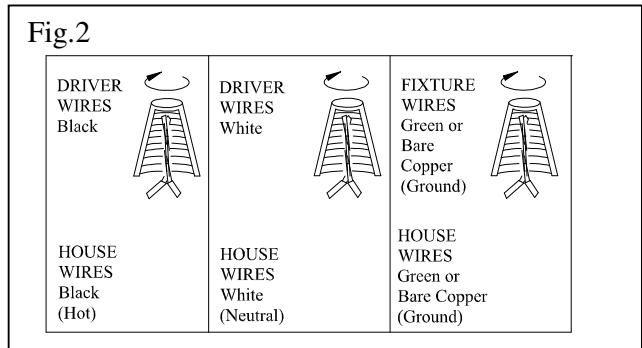
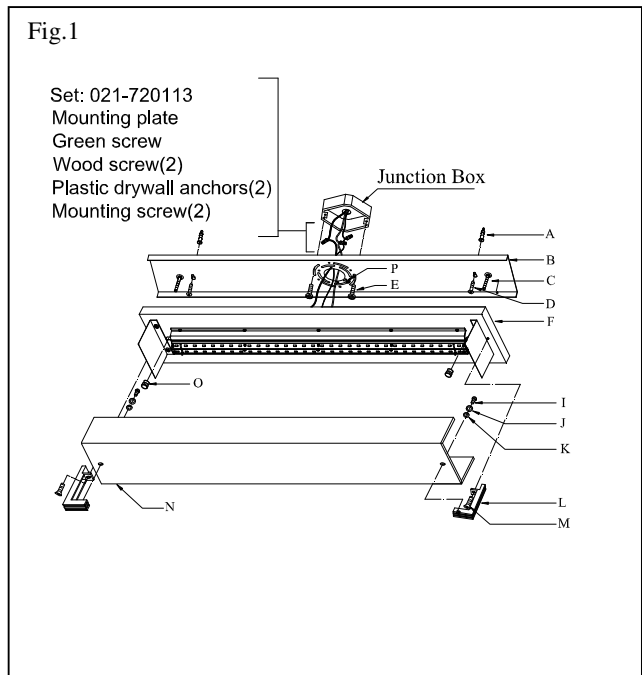

IMPORTANT: Fixture should be installed by a qualified electrician to ensure proper wiring and installation.

Dimmable with ELV and/or LED compatible wall dimmer switches.

