

Comfort, Quality & Style Since 1998

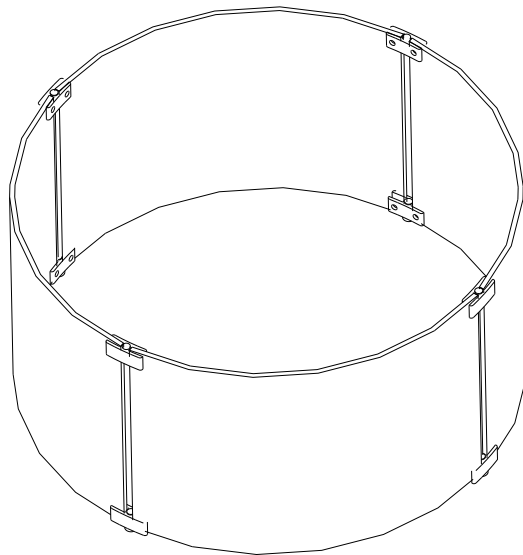

## Round Glass Guard

Item#: 63246



### ATTACH YOUR RECEIPT HERE

Keep a copy of your proof of purchase or order confirmation which will be needed if you need to contact us about warranty coverage.

Purchase Date: \_\_\_\_\_



### SAVE THESE INSTRUCTIONS FOR FUTURE REFERENCE.



### Questions, problems, missing parts?

Before returning to your retailer, our exceptional customer service is available. *English and Spanish speaking.*

Call toll-free	<b>(866) 985-7877</b>	9 a.m. – 9 p.m., EST
Email	<a href="mailto:cservice@welltraveled.net">cservice@welltraveled.net</a>	
Live chat	<a href="http://www.wtliving.com">www.wtliving.com</a>	9 a.m. – 4 p.m., EST, Monday – Friday



## BEFORE YOU BEGIN

Before beginning assembly, make sure all parts are present. Compare parts received with the "Package Contents." If any part is missing or damaged, do NOT attempt to assemble the product. Please read and understand this entire manual before attempting to assemble, operate or install this product. If you have any questions regarding the product, please contact customer service.



## SAFETY INFORMATION

### WARNING

DO NOT stand or allow children to stand on the assembled product. DO NOT tighten bolts completely until instructed to do so. After final alignment, make sure all hardware is securely fastened. NEVER use a power tool to assemble or tighten your item. Perform periodic checks to make sure the hardware is secure and tighten if needed.

### CAUTION

READ all instruction before beginning assembly. Failure to do so may result in faulty assembly and potential injury. Assemble the item on a soft, non-abrasive surface such as a carpet or cardboard to avoid damaging the item.

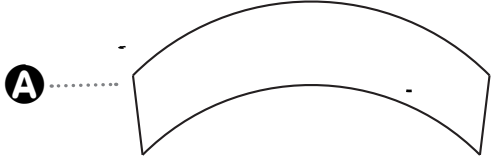

PART	DESCRIPTION	QUANTITY
<b>A</b>	Glass Panel	4



**HARDWARE CONTENTS**

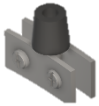

**B**  
**Bottom Bracket**  
 Qty: 5  
 (4 for assembly + 1 extra)



**C**  
**Top Bracket**  
 Qty: 5  
 (4 for assembly + 1 extra)



**D**  
**Screwdriver**  
 Qty: 1





## PREPARATION

Before beginning assembly, be sure to empty contents of carton and make sure all parts are present. If any parts are missing, please contact Customer Service.

Carefully remove the wind guard from the packaging and inspect for any damage such as chips or cracks. Place glass panels on a soft, flat surface to prevent any damage. Before assembly, ensure that each bracket has 2 set-screws, with silicon inserts attached at the tip. Estimated Assembly Time: 30 Minutes | DO NOT over tighten hardware!

- You will assemble the wind guard upside-down.

Loosen the set-screws in one **Top Bracket** , then slide two **Glass Panels**  into the bracket as shown.

Align bracket with lower edges of each glass panel. Ensure small silicone pad is in place at tip of each set-screw – **do NOT tighten metal screw directly to the glass. Over-tightening may break glass!**

Tighten set-screws until snug.

Hardware Used:  Top Bracket x1

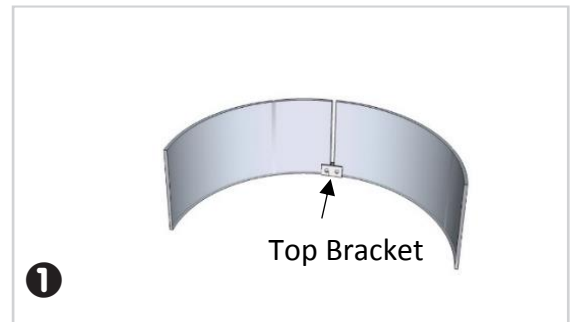

- Continue to join **Glass Panels** one at a time by the same procedure as in Step 1 until all four panels are in place to form a complete circle. Once all four **Glass Panels** and top brackets are in place, check the tightness of all 8 set-screws.

Hardware Used:  Top Bracket x3



**3** Loosen set-screws and carefully slide **Bottom Bracket B** onto glass with rubber foot pointed up. Position edge of glass panel flush with bracket edge. Check that silicone guards are in place, then secure all set-screws, making sure to not over-tighten. Secure remaining three bottom brackets using the same procedure.

**Hardware Used:**      ¼" Bottom Bracket x4

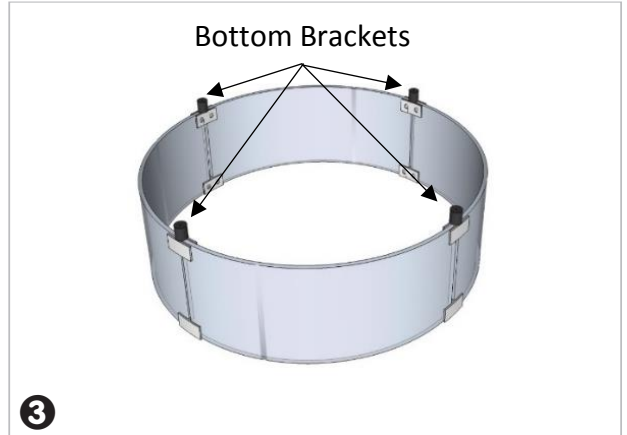

**4** Carefully, using two people, turn the assembled wind guard upright. Gently set the glass guard onto fire pit, positioning the feet flat and level at the edges of the burner.

Be aware that the glass and hardware may become warm or hot after prolonged burning of the fire pit and take reasonable precautions to avoid burns.

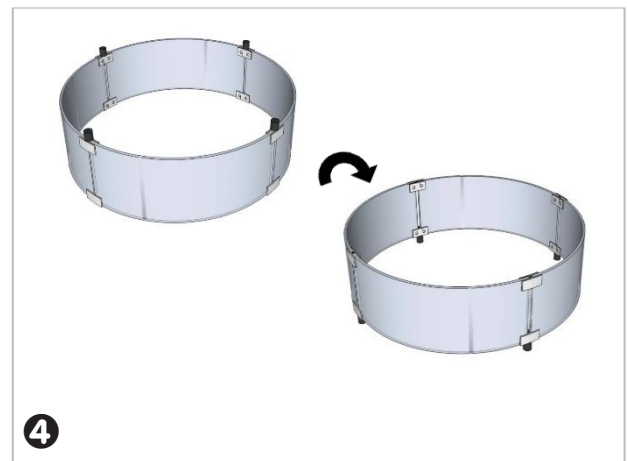

**CARE:** When wind guard is completely cool, it may be cleaned with a soft cloth or paper towel and standard glass cleaner. Never spray cleaner or water on a hot wind guard, as it could crack or shatter.



**BALKENE**  
—HOME—



## LIMITED WARRANTY

Customers in the Contiguous US

This product is warranted for a period of 1 year from original purchase date against defects in materials and workmanship under normal use. This warranty does NOT cover normal wear/weathering, exposure to water, freezing temperatures, oils, fluids, or chemicals, OR use in a commercial application if model is not designated as a commercial model. At Well Traveled Living's sole discretion, products under warranty will be repaired and/or replaced at no charge to the customer. Returns sent back to Well Traveled Living must be sent via prepaid freight in the original retail packaging.

For warranty service, contact Well Traveled Living at the address, phone numbers or website and email listed in this owner's manual. Be sure to have your sales receipt, date of purchase and catalogue/model numbers available when calling. All warranty service will be coordinated by Well Traveled Living's, Amelia Island, Florida service center. This warranty is extended only to the original owner. Proof of purchase will be required before warranty service is rendered. The sales receipt is the only valid proof of purchase. This warranty only covers failures due to defects in materials or workmanship which occur during normal use. Failures and/or damage which result from accident, negligence, misuse, abuse, neglect, mishandling, alteration or modification, failure to maintain, improper assembly or maintenance, service by unauthorized agency or use of unauthorized components or damage that is attributable to acts of God are NOT covered.

This limited warranty gives you specific legal rights and you may also have other rights which vary from jurisdiction to jurisdiction. The provisions of the United Nations Convention on Contracts for the Sales of Goods shall not apply to this limited warranty or the sale of products covered by this limited warranty.

- THERE ARE NO EXPRESS WARRANTIES EXCEPT AS LISTED
- PURCHASER ASSUMES ALL RISKS IN THE ASSEMBLY AND OPERATION OF THIS UNIT
- FAILURE TO FOLLOW WARNINGS AND OPERATIONAL INSTRUCTIONS CONTAINED IN THIS MANUAL CAN RESULT IN SEVERE PROPERTY DAMAGE AND/OR PERSONAL INJURY
- IN NO EVENT WILL WELL TRAVELED LIVING, OR ITS DIRECTORS, OFFICERS OR AGENTS BE LIABLE TO THE PURCHASER OR ANY THIRD PARTY, WHETHER IN CONTRACT, IN TORT, OR ON ANY OTHER BASIS, FOR ANY INDIRECT, SPECIAL, PUNITIVE, EXEMPLARY, CONSEQUENTIAL, OR INCIDENTAL LOSS, COST, OR DAMAGE ARISING OUT OF OR IN CONNECTION WITH THE SALE, MAINTENANCE, USE, OR INABILITY TO USE THE PRODUCT, EVEN IF WELL TRAVELED LIVING OR ITS DIRECTORS, OFFICERS OR AGENTS HAVE BEEN ADVISED OF THE POSSIBILITY OF SUCH LOSSES, COSTS OR DAMAGES, OR IF SUCH LOSSES, COSTS, OR DAMAGES ARE FORESEEABLE. IN NO EVENT WILL WELL TRAVELED LIVING, OR ITS OFFICERS, DIRECTORS, OR AGENTS BE LIABLE FOR ANY DIRECT LOSSES, COSTS OR DAMAGES THAT EXCEED THE PURCHASE PRICE OF THE PRODUCT.
- SOME JURISDICTIONS DO NOT ALLOW THE EXCLUSION OR LIMITATION OF INCIDENTAL OR CONSEQUENTIAL DAMAGES, SO THE ABOVE LIMITATION OR EXCLUSION MAY NOT APPLY TO THE PURCHASER.

## EXTEND YOUR WARRANTY

When you purchase a Fire Sense or Balkene Home product, you have the peace of mind in knowing that it comes with a one-year warranty. Extend your warranty for *an additional year* when you write a review of your purchase on [www.wtliving.com](http://www.wtliving.com) within 365 days of purchase.



### Important Notice

Do NOT return to place of purchase—for customer service and warranty issues contact our Customer Service Center at (866) 985-7877 or [cservice@welltraveled.net](mailto:cservice@welltraveled.net), or go online and live chat at [wtliving.com](http://wtliving.com). Hours are: 9 a.m. – 6 p.m., EST, Monday – Friday.

Distributed by:

Well Traveled Living  
716 S 8th Street, Amelia Island, FL 32034  
[wtliving.com](http://wtliving.com) | [cservice@welltraveled.net](mailto:cservice@welltraveled.net)  
(866) 985-7877