



# OWNER'S MANUAL

## Tabletop Heater

### **Safety First!**

*Read and become familiar  
with this entire manual.*

#### **WARNING**

This product can expose you to chemicals including carbon monoxide which is known to the State of California to cause birth defects or other reproductive harm. For more information go to [www.P65Warnings.ca.gov](http://www.P65Warnings.ca.gov).



*Please retain this manual for reference*



## TABLE OF CONTENTS

• Read These Safety Instructions.....	1
• Contents Breakdown.....	2
• Screw Packing List.....	3
• Assembly Procedure.....	3
• Assembly.....	4
• Safety First.....	7
• Tabletop Heater Location.....	8
• Checking For Leaks.....	8
• Before Operating.....	8
• Operating.....	9
• After Operating.....	11
• Maintenance.....	11
• Storage.....	11
• Troubleshooting.....	12

## READ THESE SAFETY INSTRUCTIONS

If you smell gas:

- Shut off gas to the appliance.
- Extinguish any open flame.
- If odor continues, immediately call your gas supplier or your Fire Department.

### WARNING

Failure to comply with these instructions could result in a fire or explosion that could cause serious bodily injury, death, or property damage.

### ATTENTION

- Only to be used outdoors.
- Warning: Accessible parts may be very hot. Keep young children away.
- Turn off the gas supply at the gas container after use.
- Any modification of the appliance may be dangerous.

### FOR YOUR SAFETY

- Gas leaks may cause a fire or explosion that can cause serious bodily injury or death, or damage to property.
- You must follow all leak checking procedures before operating this unit.
- Never use an open flame to check for leaks.

### WARNING

Do not store or use gasoline or other flammable vapors or liquids in the vicinity of this or any other appliance.

Danger: Carbon Monoxide hazard:

1. This appliance can produce carbon monoxide which has no odor.
2. Using it in an enclosed space can kill you.
3. Never use this appliance in an enclosed space such as a camper, tent, car or home.
  - Do NOT touch or move heater for at least 45 minutes after use.
  - Dome is hot to the touch.
  - Allow dome to cool completely before touching.

# CONTENTS BREAKDOWN

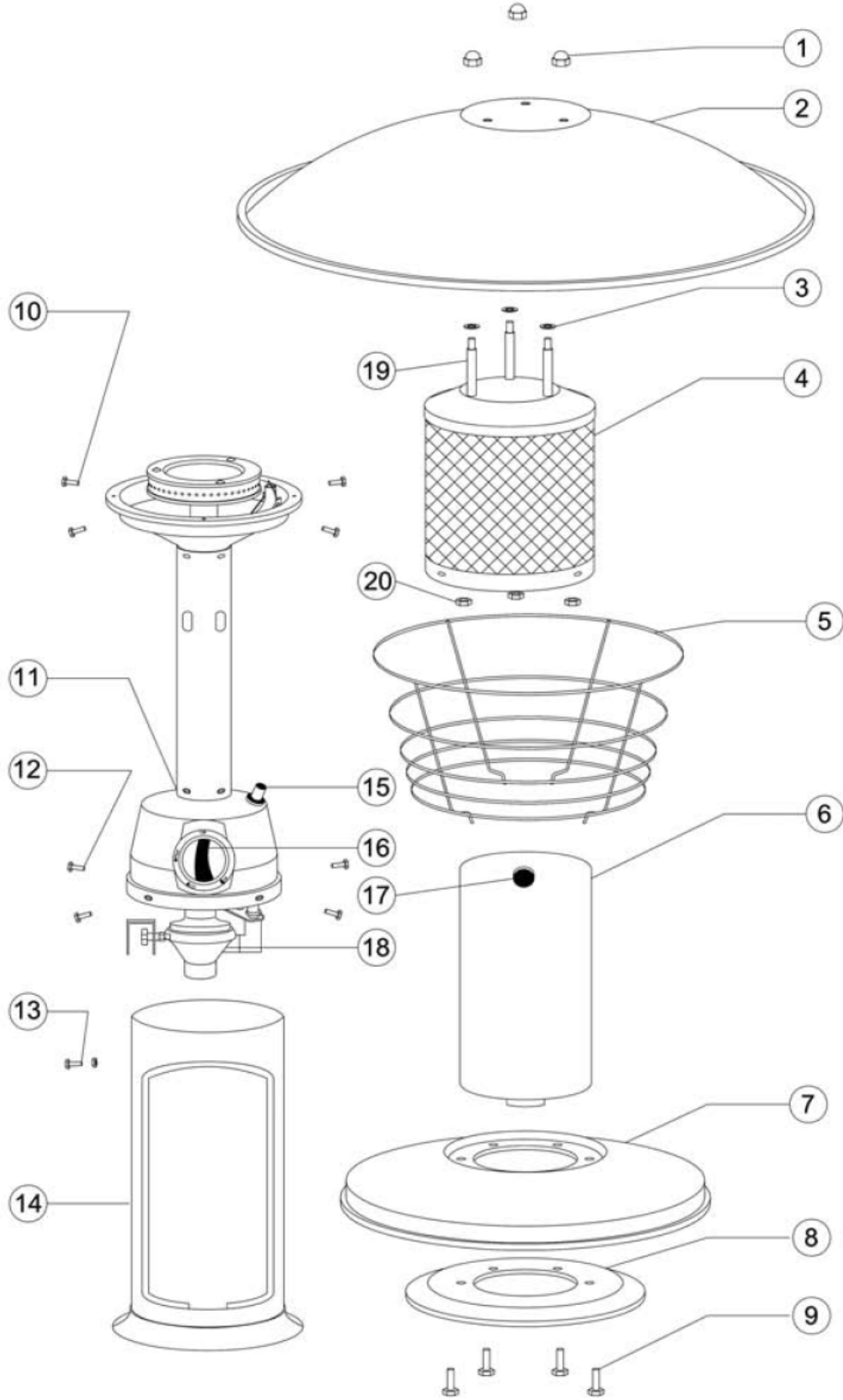

Item No.	Item	Qty.	Item No.	Item.	Qty.
1	M6 Castle nut	3	11	Burner	1
2	Reflector	1	12	3/16" bolt	4
3	6mm Washer	3	13	M5x10mm bolt	1
4	Emitter screen	1	14	Tank Housing	1
5	Guard	1	15	Igniter button	1
6	Door Plate	1	16	Control knob	1
7	Base	1	17	Handle	1
8	Cast Iron weight	1	18	Regulator	1
9	M6x15mm bolt	4	19	60mm pin	3
10	3/16" bolt	4	20	M6 flange nut	3

### SCREW PACKAGING LIST

Item	Qty.	Item	Qty.
M6 Castle Nut	3	M5x10mm bolt & M5 nut	1
6mm washer	6	60mm pin	3
M6x15mm bolt	4	M6 flange nut	3
3/16" bolt	8	Wrench	1

### ASSEMBLY PROCEDURE

**Tools needed:** (not included)

- Adjustable opening wrench (2) 20 cm long
- Slip joint pliers 23 cm long
- Philips screwdriver w/medium blade

## ASSEMBLY

### STEP 1



1-1. Remove all parts of the heater from the packaging. (NOTE: Plastic ring on tank housing should already be in place but if it is not, slide the plastic ring over the bottom of tank housing.)



### STEP 2



2-1. Use 4 pcs M6x15mm bolts to fix the tank housing to the base and cast iron weight (Note: weight is preassembled to base).

2-2. Tighten the bolts as shown above.

### STEP 3



3-1. Put the burner on the tank housing then fix them with 4 pcs 3/16" bolts.

### STEP 4



4-1. Fix the regulator to the tank housing with the M5x10mm bolt and M5 nut.

**STEP 5**

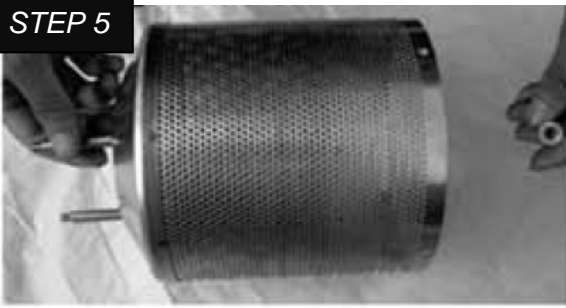

5-1. Fix 3 pcs pins of 60mm length to the emitter screen with 3 pcs flange nuts then tighten them.

**STEP 6**



6-1. Put the emitter screen on the burner.  
6-2. Use 4 pcs 3/16" bolts to connect the emitter screen to the burner. Tighten the bolts.

**STEP 7**



7-1. Put the guard on the burner over the emitter screen.  
7-2. Put the ends of the guards into the holes of the burner.

**STEP 8**

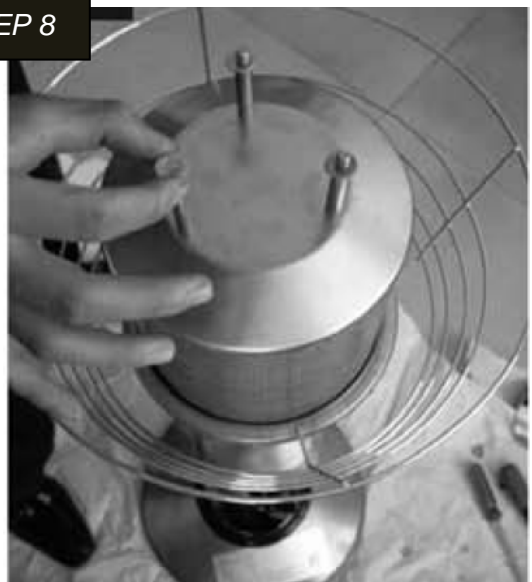

8-1. Put 3 pcs washers on each pin of the 60mm length.

**STEP 9**



9-1. Put the reflector through the pins and on the washers.

**STEP 10**



10-1. Fasten the reflector with 3 pcs M6 castle nuts.

**STEP 11**



11-1. Turn off the control knob of the burner.  
11-2. Fix the 1.02 lbs. gas tank (not included) to the regulator (rotate the gas tank clockwise toward the regulator until tightened).

**STEP 12**



12-1. Close the door plate and lock it with the handle (rotate the handle 90 degrees)



## SAFETY FIRST

### **Read and become familiar with this entire manual, especially the following precautions:**

Caution: This appliance is for outdoor use only (outside any enclosure).

Always make sure there is fresh air ventilation.

- Use only outdoors in a well ventilated space. Never use in a building, garage or any other enclosed area.
- Always maintain at least 18" clearance (top) and 24" clearance (side) from combustible materials.
- Always place heater on a hard and level surface.
- Do not use if the wind velocity is greater than 10 miles per hour.
- Unit will operate at decreased efficiency below 40 degrees F (5 degrees C).
- Keep sprinklers and other water sources away from burner and controls.
- Always use extreme caution when near heater. Alert both children and adults to the hazards of high temperatures, especially to avoid burns or clothing catching fire.
- Young children and pets should be carefully supervised when they are in the area of heater.
- Do not place clothing or other flammable materials on or near heater.
- Any guard or other protective device removed for servicing the heater must be replaced prior to operating the heater.
- Certain materials or items, when stored under heater, will be subjected to radiant heat and could be seriously damaged.
- Do not alter heater in any manner.
- Inspect heater before each use. If a damaged part is detected, do not operate until an original equipment replacement part has been properly installed. Use of unauthorized parts will void warranty and create an unsafe condition.
- Do not attempt to use this appliance without a functional factory supplied gas regulator in place. If regulator becomes damaged, use only a factory supplied replacement.
- Prior to operating heater, replace any guards or protective devices removed for servicing.
- During operation, do not touch burner assembly. The surface of heater's emitter can reach temperatures approaching 1600 degrees F.
- After shutdown, do not touch burner assembly until heater has cooled completely (approximately 45 minutes after use).

## TABLETOP HEATER LOCATION

- The tabletop heater is for outdoor use only. Always ensure that adequate fresh air ventilation is provided.
- Always maintain proper clearance to combustible materials, i.e. top 18" and sides 24" minimum.
- Tabletop heater must be located on a stable and strong surface.
- Never operate heater in an explosive atmosphere like in areas where gasoline or other flammable liquids or vapors are stored.

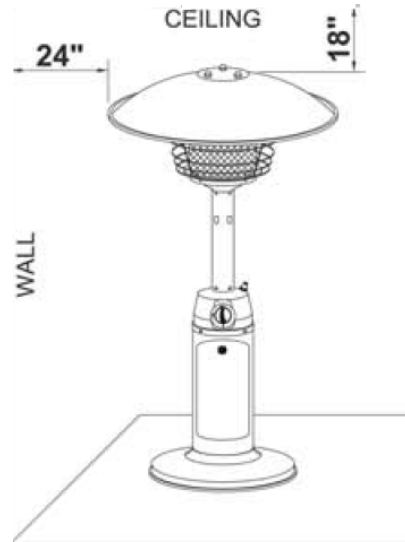

## CHECKING FOR LEAKS

Make 1-2 oz. of leak solution by mixing one part liquid dishwashing soap and 3 parts water.

Spoon several drops (or use squirt bottle) of the solution onto the regulator/canister connections.

Inspect the connections and look for bubbles.

If NO bubbles appear, the connection is safe.

If bubbles appear, there is a leak:

- Loosen and re-tighten this connection.
- Re-check for leak by repeating this procedure.

If you continue to see bubbles after several attempts, disconnect the propane source.

## BEFORE OPERATING

- I am familiar with entire owner's manual and understand all precautions noted in "Safety First".
- All components are properly assembled, intact and operable.
- No alterations have been made.
- All gas connections are secure and do not leak.
- Wind velocity is below 10 mph.
- Outdoor temperature is greater than 40 degrees F.
- Heater is outdoors (outside any enclosure).
- There is adequate fresh air ventilation.
- Heater is away from gasoline or other flammable liquids or vapors.
- Heater is away from windows, air intake openings, sprinklers and other water sources.
- Heater is at least 18" clearance (top) and 24" clearance (side) from combustible materials.

- Heater is on a hard and level surface.
- There are no signs of spider or insect nests.
- All burner passages are clear.
- All air circulation passages are clear.
- Children, pets, clothing, flammable materials and items that can be damaged from radiant heat are away from the heater.
- Children and adults in the area have been alerted to the high temperature hazards; especially burns and clothing fires.
- Children and adults in the area have been warned not to touch heater near emitter during operation and until unit has cooled completely.

## OPERATION

**Inspect the heater before each operation.**

### **Before Turning Gas Supply ON**

Your heater was designed and approved for OUTDOOR USE ONLY. DO NOT use it inside a building, garage or any other enclosed area.

Make sure surrounding areas are free of combustible materials, gasoline and other flammable liquids.

- Ensure that there is no obstruction to air ventilation.
- Be sure all gas connections are tight and there are no leaks.
- Be sure the access panel is clear of debris
- Be sure any component removed during assembly or servicing is replaced prior to starting.

### **Before Lighting**

Heater should be thoroughly inspected before each use and by a qualified service person at least annually.

If relighting a hot heater, always wait at least 5 minutes for gas to dissipate.

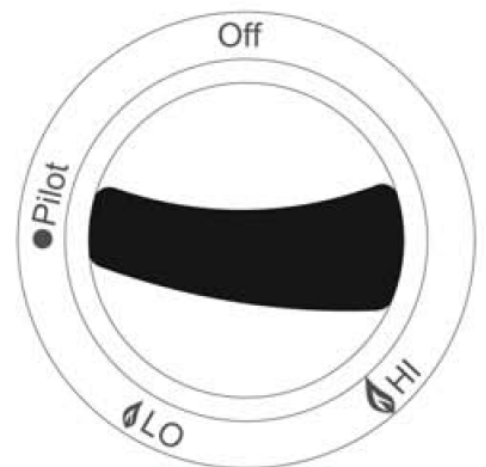
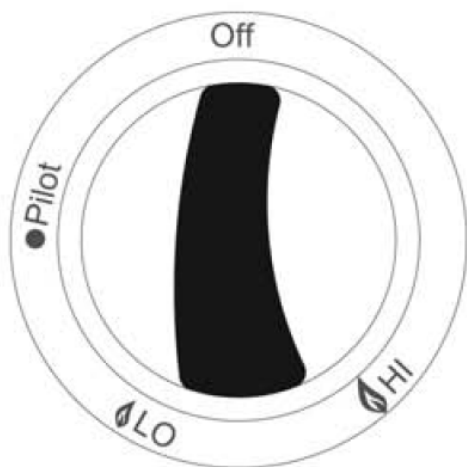

### **Lighting**

1. Make sure control knob is in the “Off” position.
2. Push in and rotate the gas control knob to “Pilot” position. Depress gas control knob for 30 seconds to allow air to purge. Once gas reaches burner, depress igniter button while holding gas control knob in.
3. Once burner is lit, hold control knob in for at least 30 seconds and release.
4. If burner does not stay lit, turn control knob to “Off” position and wait 5 minutes and repeat 2 and 3.
5. Once burner is lit, rotate control knob to desired heating level (LO: low; HI: high).

If you experience any ignition problem, turn off the heater and gas supply and consult “Troubleshooting” on page 12.

### **Caution**

**Avoid inhaling fumes emitted from heater’s first use. Smoke and odor from the burning of oils used in manufacturing will appear. Both smoke and odor will dissipate after approximately 30 minutes. The heater should NOT produce thick black smoke.**

*Note: The burner may be noisy when initially turned on. To eliminate excessive noise from the burner, turn the control knob to LO position. Then, turn the knob to level of heat desired.*

### **When heater is ON:**

Emitter screen will become bright red due to intense heat. The color is more visible at night.

Burner will display tongues of blue flame. These flames should not be yellow or produce thick black smoke, indicating an obstruction of airflow through the burners.

If yellow flame is detected, turn off heater and gas supply and consult “Troubleshooting” on page 12.

### **Re-lighting**

Note: For your safety, control knob cannot be turned to “Pilot” without first depressing control knob in “Off” position and then rotating to “Pilot”.

1. Turn gas control knob to “Off”.
2. Wait 5 minutes to let gas dissipate before attempting to relight burner.
3. Repeat the “Lighting” steps 2 and 3.

### **To turn heater OFF:**

1. Rotate gas knob to “Off” position. Normally, burner will make a slight popping sound when extinguished.
2. Remove door plate.
3. Unscrew gas canister from regulator and store gas canister AWAY from heater when heater is not in use.
4. Close door plate.

Note: After use, some discoloration of the emitter screen is normal.

## AFTER OPERATING

### **Make sure:**

- Gas control is in OFF position.
- Unscrew gas canister from regulator and store gas canister AWAY from heater when heater is not in use.
- Store heater in an upright position in a secure location.

## MAINTENANCE

- To enjoy years of outstanding performance from your heater, make sure you perform the following maintenance activities on a regular basis.
- Air flow must be unobstructed. Keep controls, burner, and circulating air passageways clean. Signs of possible blockage include: Gas odor with extreme yellow tipping of flame; heater does NOT reach the desired temperature; heater glow is excessively uneven.
- Spiders and insects can nest in burner or orifices. This can cause the heater to make popping noises. This dangerous condition can damage heater and render it unsafe for use. Clean burner holes by using a heavy-duty pipe cleaner.
- Compressed air may help clear away smaller particles.
- Carbon deposits may create a fire hazard. Clean dome and emitter with warm soapy water if any carbon deposits develop.

Note: In a salt air environment (such as near an ocean), corrosion occurs more quickly than normal.

- Frequently check for corroded areas and repair them promptly.
- Keep exterior surfaces clean.

## STORAGE

### **Between uses:**

- Turn control knob to “OFF” position.
- Unscrew gas canister from regulator and store gas canister AWAY from heater when heater is not in use.
- Store heater upright in an area sheltered from direct contact with inclement weather (such as rain, sleet, hail, snow) and debris.

If desired, cover heater to protect exterior surfaces and to help prevent build up in air passages.

NOTE: Wait until heater is completely cooled before covering.

### **During periods of extended inactivity or when transporting:**

- Turn control knob to “OFF” position.
- Unscrew gas canister from regulator and store gas canister AWAY from heater when heater is not in use.
- Store heater upright in an area sheltered from direct contact with inclement weather (such as rain, sleet, hail, snow) and debris.

If desired, cover heater to protect exterior surfaces and to help prevent build up in air passages.

## TROUBLESHOOTING

PROBLEM	PROBABLE CAUSE	SOLUTION
<b>Pilot will not light</b>	Fuel canister empty Opening blocked Air in supply system Loose connections	Replace fuel canister Clean opening Purge air from system Check all fittings
<b>Pilot will not stay on</b>	Debris around pilot Loose connections Gas leak Lack of fuel pressure	Clean dirty area Tighten connections Check connections Canister near empty. Replace fuel canister.
<b>Burner will not light</b>	Pressure is low  Opening blocked Control not ON Pilot light assembly bent Not in correct location	Canister near empty. Replace fuel canister. Remove and clean Turn knob to ON Place pilot properly Position properly and retry

**Distributed By:**

Well Traveled Living  
716 S 8<sup>th</sup> Street  
Amelia Island, FL 32034  
Toll Free: 866-WTL-SUPP



Web: [www.wtliving.com](http://www.wtliving.com)  
Email: [cservice@welltraveled.net](mailto:cservice@welltraveled.net)

**1 YEAR LIMITED WARRANTY – Customers in the Continental US**

All components are warranted for a period of 1 year after date of purchase by the original owner against defects in materials and workmanship under normal use. This warranty does NOT cover normal wear and weathering, assembly and/or maintenance OR use in a commercial application. At Well Traveled Living's sole discretion, products under warranty will be repaired and/or replaced at no charge to the customer. Any returns sent back to Well Traveled Living must be sent via prepaid freight and in the original retail packaging.

For warranty service contact Well Traveled Living at the address, phone numbers or internet site and email listed in this owner's manual. Be sure to have your sales receipt, date of purchase and catalogue/model numbers available when calling. All warranty service will be coordinated by the Well Traveled Living's, Amelia Island, Florida service center.

This warranty is extended only to the original purchaser. Proof of purchase will be required before warranty service is rendered. The sales receipt is the only valid proof of purchase. This warranty only covers failures due to defects in materials or workmanship which occur during normal use. Failures and/or damage which result from accident, negligence, misuse, abuse, neglect, mishandling, alteration or modification, failure to maintain, improper assembly or maintenance, service by unauthorized agency or use of unauthorized components or damage that is attributable to acts of God are NOT covered.

**\*\*\*THERE ARE NO EXPRESS WARRANTIES EXCEPT AS LISTED ABOVE\*\*\***

**\*\*\*PURCHASER ASSUMES ALL RISKS IN THE ASSEMBLY AND OPERATION OF THIS UNIT\*\*\***

**\*\*\*FAILURE TO FOLLOW WARNINGS AND OPERATIONAL INSTRUCTIONS CONTAINED IN THIS MANUAL CAN RESULT IN SEVERE PROPERTY DAMAGE AND/OR PERSONAL INJURY\*\*\***

**IN NO EVENT WILL WELL TRAVELED LIVING, OR ITS DIRECTORS, OFFICERS OR AGENTS BE LIABLE TO THE PURCHASER OR ANY THIRD PARTY, WHETHER IN CONTRACT, IN TORT, OR ON ANY OTHER BASIS, FOR ANY INDIRECT, SPECIAL, PUNITIVE, EXEMPLARY, CONSEQUENTIAL, OR INCIDENTAL LOSS, COST, OR DAMAGE ARISING OUT OF OR IN CONNECTION WITH THE SALE, MAINTENANCE, USE, OR INABILITY TO USE THE PRODUCT, EVEN IF WELL TRAVELED LIVING OR ITS DIRECTORS, OFFICERS OR AGENTS HAVE BEEN ADVISED OF THE POSSIBILITY OF SUCH LOSSES, COSTS OR DAMAGES, OR IF SUCH LOSSES, COSTS, OR DAMAGES ARE FORESEEABLE. IN NO EVENT WILL WELL TRAVELED LIVING, OR ITS OFFICERS, DIRECTORS, OR AGENTS BE LIABLE FOR ANY DIRECT LOSSES, COSTS OR DAMAGES THAT EXCEED THE PURCHASE PRICE OF THE PRODUCT.**

**SOME JURISDICTIONS DO NOT ALLOW THE EXCLUSION OR LIMITATION OF INCIDENTAL OR CONSEQUENTIAL DAMAGES, SO THE ABOVE LIMITATION OR EXCLUSION MAY NOT APPLY TO THE PURCHASER.**

This limited warranty gives you specific legal rights and you may also have other rights which vary from jurisdiction to jurisdiction. The provisions of the United Nations Convention on Contracts for the Sales of Goods shall not apply to this limited warranty or the sale of products covered by this limited warranty.

**\*\*\*IMPORTANT NOTICE\*\*\***

-Do **NOT** return to place of purchase-  
For customer service and warranty issues  
contact our Customer Service Center at:  
(866)-985-7877 OR

Email: [cservice@welltraveled.net](mailto:cservice@welltraveled.net)

Customer Service Hours: Mon. – Fri. 9:00 a.m. – 6:00 p.m. (EST)