

# RAPPORT DE SPÉCIFICATIONS DE PRODUIT

NOM DU PROJET: \_\_\_\_\_

INFORMATION SUPPLÉMENTAIRE: \_\_\_\_\_

QUANTITÉ REQUISE: \_\_\_\_\_

NUMÉRO DE PRODUIT: **204042A**

## DÉTAILS DU PRODUIT

- **Type de luminaire:** Murale DEL
- **Largeur:** 27 1/2" (700 mm)
- **Hauteur:** 5 3/4" (145 mm)
- **Profondeur:** 5 1/4" (132 mm)
- **Canopée:** 5 3/8" (135 mm) x 4 1/2" (115 mm) x 1 3/4" (45 mm)
- **Poids:** 4.409 lbs. (2.270 kgs.)
- **Puissance en watts (maximum):** 21.8W
- **Type d'ampoule:** DEL
- **Lumens:** 2230
- **Kelvin:** 3000K
- **Fini:** Chrome
- **Abat-jour:** Acrylique Satin
- **Matériel:** Acier avec abat-jour en acrylique
- **Type d'installation:** Relié à la boîte électrique

## QUALIFICATIONS

- c-UL-us et c-ETL-us Liste
- Convient aux emplacements humides et secs

## FEUILLES D'INSTRUCTIONS

- Français et anglais inclus

## AUTRES INFORMATIONS

- **UPC:** 9008606200139
- **Nom du produit:** Metrass 3
- **Pièces de remplacement:** GL2497

## PHOTO

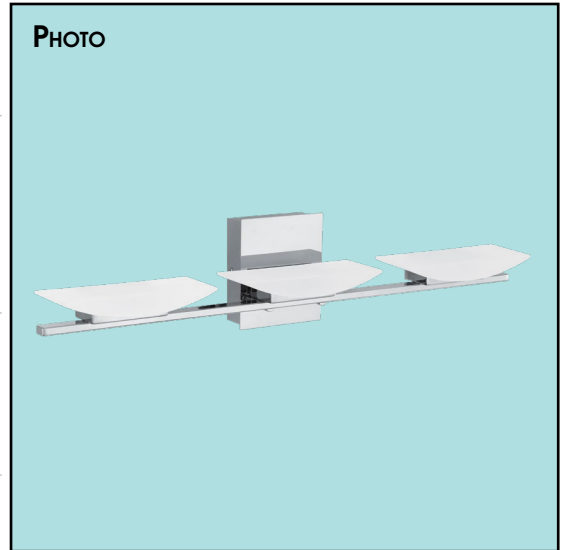

## DESSIN DE LIGNE

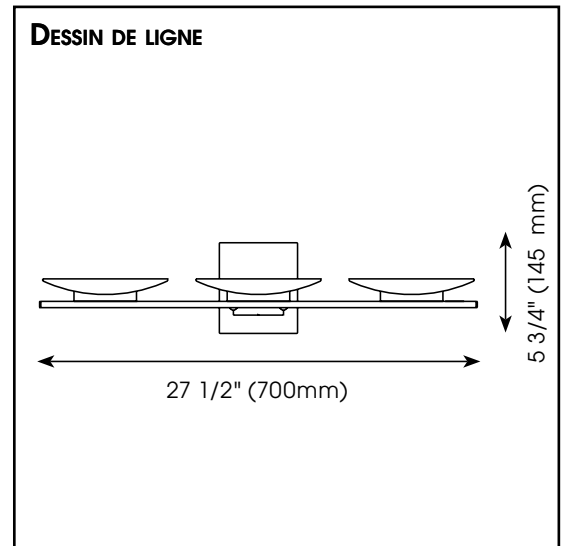

EGLO Canada



# PRODUCT SPECIFICATIONS REPORT

PROJECT NAME: \_\_\_\_\_

ADDITIONAL INFORMATION: \_\_\_\_\_

QUANTITY REQUIRED: \_\_\_\_\_

PRODUCT NUMBER: **204042A**

## PRODUCT DETAILS

- **Fixture Type:** LED Wall Light
- **Width:** 27 1/2" (700 mm)
- **Height:** 5 3/4" (145 mm)
- **Depth:** 5 1/4" (132 mm)
- **Canopy:** 5 3/8" (135 mm) x 4 1/2" (115 mm) x 1 3/4" (45 mm)
- **Weight:** 4.409 lbs. (2.270 kgs.)
- **Bulb Wattage (maximum):** 21.8W
- **Bulb Type:** LED
- **Lumens:** 2230
- **Kelvin:** 3000K
- **Finish:** Chrome
- **Shade:** Satin Acrylic
- **Material:** Steel with Acrylic Shade
- **Installation Type:** Hardwire (Standard 4" Outlet Box)

## PHOTO



## LINE DRAWING

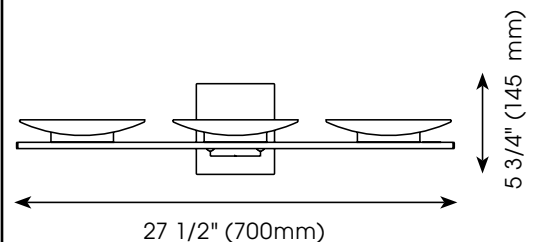

## QUALIFICATIONS

- c-UL-us and c-ETL-us Listed
- Suitable for damp and dry locations

## INSTRUCTION SHEETS

- Included in English & French

## OTHER INFORMATION

- **UPC:** 9008606200139
- **Series Name:** Metrass 3
- **Replacement Part:** GL2497

EGLO Canada

20700 route Transcanadienne | Baie-D'Urfé | Québec | Canada | H9X 4B7 | Tel. 514-457-5483 | Fax 514-457-5487 | E-Mail: info-canada@eglo.com | www.eglo.com

