

RAPPORT DE SPÉCIFICATIONS DE PRODUIT

NOM DU PROJET: _____

INFORMATION SUPPLÉMENTAIRE: _____

QUANTITÉ REQUISE: _____

NUMÉRO DE PRODUIT: **203246A**

DÉTAILS DU PRODUIT

- **Type de luminaire:** Luminaire sur rail DEL
- **Longueur:** 15 3/8" (390 mm)
- **Largeur:** 4 1/2" (115 mm)
- **Hauteur:** 5 5/8" (143 mm)
- **Canopé:** 5 3/8" (135 mm) x 4 1/2" (115 mm) x 0.06" (1 mm)
- **Poids:** 2.050 lbs. (0.930 kgs.)
- **Puissance en watts (maximum):** 2 x 5W
- **Type d'ampoule:** GU10 DEL
- **Lumens:** 2 x 450 (900)
- **Kelvin:** 3000K
- **Fini:** Nickel mat
- **Abat-jour:** Nickel mat
- **Matériel:** Acier
- **Type d'installation:** Relié à la boîte électrique

QUALIFICATIONS

- c-UL-us et c-ETL-us Liste
- Convient aux emplacements secs et humides
- Plafonnier et murale

FEUILLES D'INSTRUCTIONS

- Français et anglais inclus

AUTRES INFORMATIONS

- **UPC:** 9008606190607
- **Nom du produit:** Trillo 1
- **Verre de Remplacement:** N/A

PHOTO

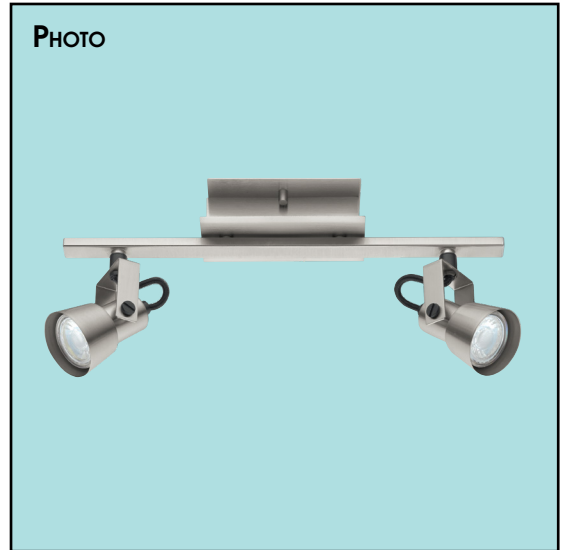

DESSIN DE LIGNE

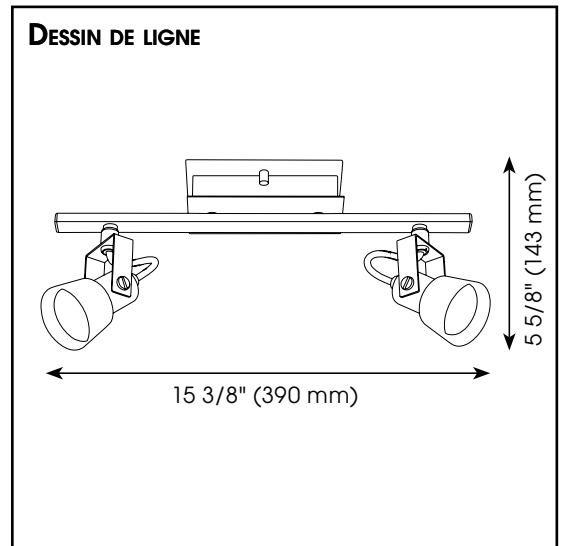

EGLO Canada



PRODUCT SPECIFICATIONS REPORT

PROJECT NAME: _____

ADDITIONAL INFORMATION: _____

QUANTITY REQUIRED: _____

PRODUCT NUMBER: 203246A

PRODUCT DETAILS

- **Fixture Type:** LED Track Light
- **Length:** 15 3/8" (390 mm)
- **Width:** 4 1/2" (115 mm)
- **Height:** 5 5/8" (143 mm)
- **Canopy:** 5 3/8" (135 mm) x 4 1/2" (115 mm) x 0.06" (1 mm)
- **Weight:** 2.050 lbs. (0.930 kgs.)
- **Bulb Wattage (maximum):** 2 x 5W
- **Bulb Type:** LED GU10
- **Lumens:** 2 x 450 (900)
- **Kelvin:** 3000K
- **Finish:** Matte Nickel
- **Shade:** Matte Nickel
- **Material:** Steel
- **Installation Type:** Hardwire (Standard 4" Outlet Box)

QUALIFICATIONS

- c-UL-us and c-ETL-us Listed
- Suitable for dry and damp locations
- Ceiling and wall mount

INSTRUCTION SHEETS

- Included in English & French

OTHER INFORMATION

- **UPC:** 9008606190607
- **Series Name:** Trillo 1
- **Glass Replacement:** N/A

PHOTO

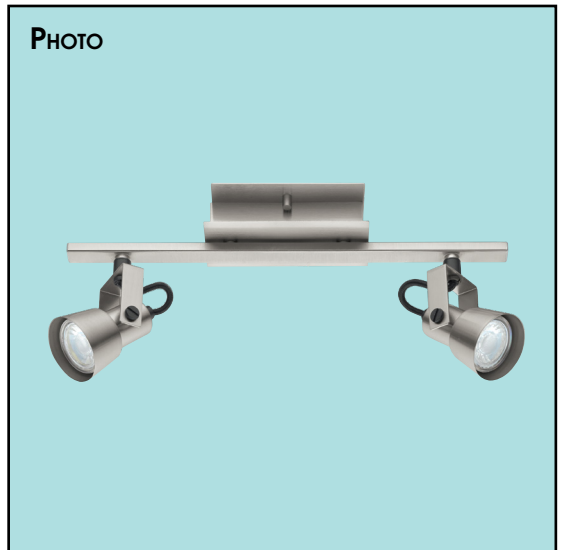

LINE DRAWING

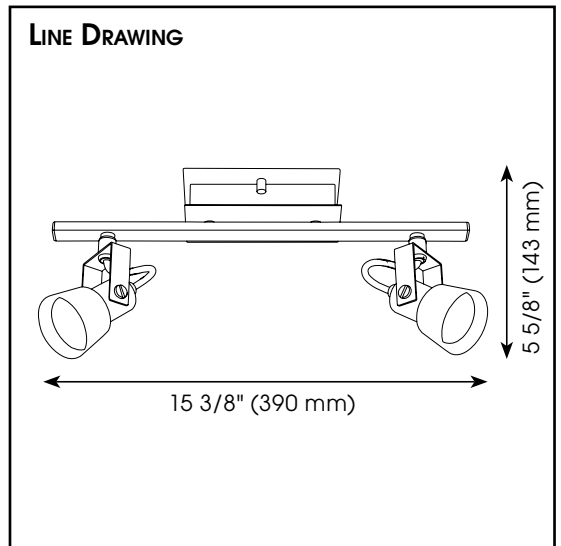

EGLO Canada

