

GM5100-FROST

POST FIXTURE

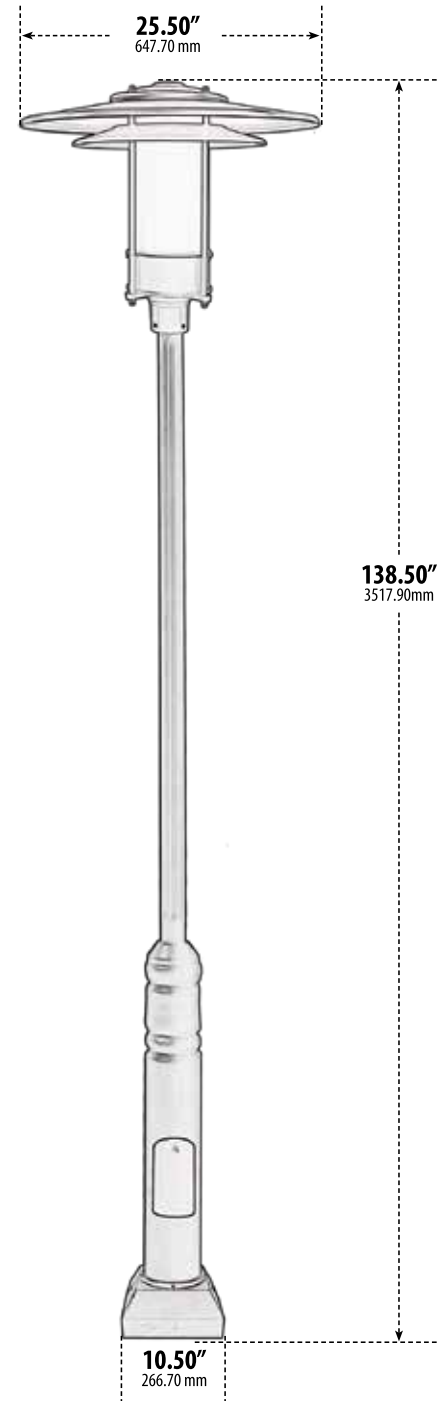
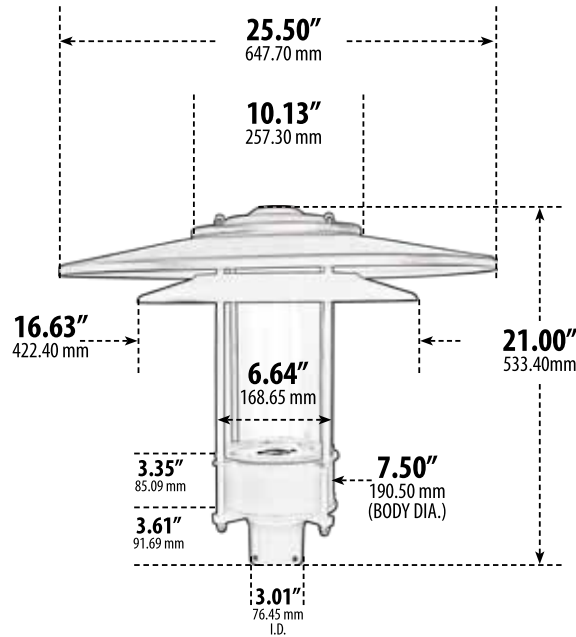

- ▶ **Material:** Powder Coated Cast Aluminum
- ▶ **Lens:** Frosted, Heat Resistant, Tempered Glass
- ▶ **Available Finish:** Black, Verde Green
- ▶ **ETL Approval Pending**

MODEL NUMBER	LAMP TYPE	ILLUMINANT TYPE	WATTS (W)	VOLTS (V)	LAMP(S) INCLUDED?
GM5100-FROST	A-Type	Incandescent	60	120	NO
GM5100-LED20-FROST	G24-LED	LED	20	120-277	YES
GM5100-LED30-FROST	Tubular LED	LED	30	85-265	YES

20W LED Available in 30K or 50K
 30W LED Available in 30K or 65K

Overall Dimensions:
 138.50"H x 25.50"W x 25.50"D

Weight: 85.42 lbs
 Approximate Wire Length: N/A



DABMAR LIGHTING INCORPORATED

320 Graves Ave . Oxnard, CA 93030 . 805.604.9090 . f: 805.604.9050 . www.dabmar.com
 4693 19th Street Ct E . Bradenton, FL 34203