

GM120-SS

WALL FIXTURE

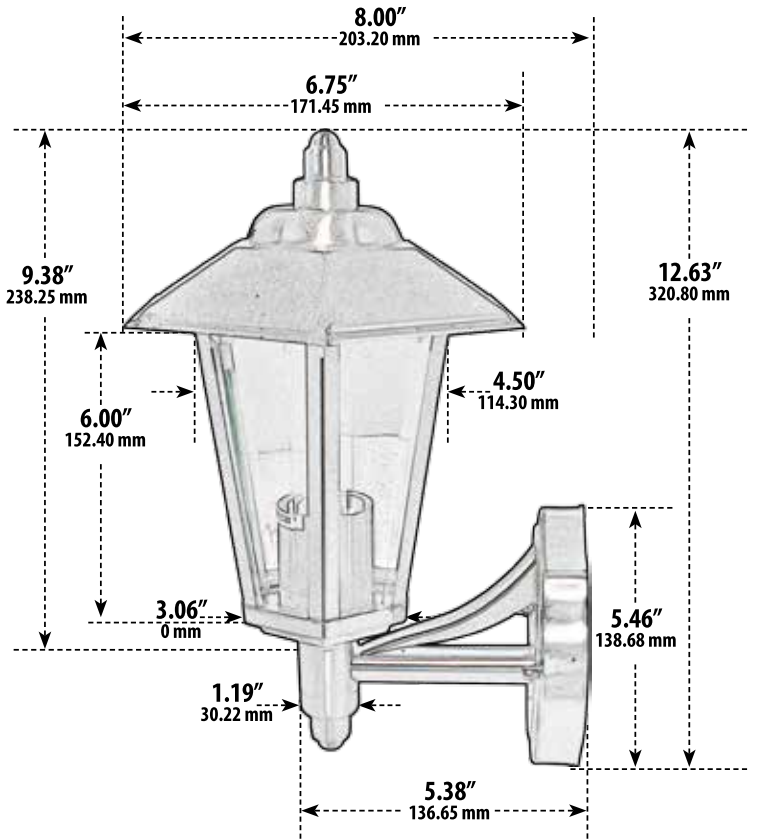

- ▶ **Material:** Stainless Steel
- ▶ **Lens:** Clear, Heat Resistant, Tempered Glass
- ▶ **Available Finish:** Stainless Steel
- ▶ **ETL Approval Pending**

MODEL NUMBER	LAMP TYPE	ILLUMINANT TYPE	WATTS (W)	VOLTS (V)	LAMP(S) INCLUDED?
GM120-SS**	A-Type	Incandescent	60	120	NO

**AVAILABLE IN 4W A19-LED Add -LED4 to Model Number

Overall Dimensions:
12.63"H x 6.75"W x 8.00"D

Weight: 2.4 lbs
Approximate Wire Length: N/A

Box Dimensions:
11.00"H x 8.63"W x 7.00"D

DABMAR
LIGHTING

DABMAR LIGHTING INCORPORATED

2140 Eastman Ave . Oxnard, CA 93030 . 805.604.9090 . f: 805.604.9050 . www.dabmar.com