

FG319

IN-GROUND WELL LIGHT

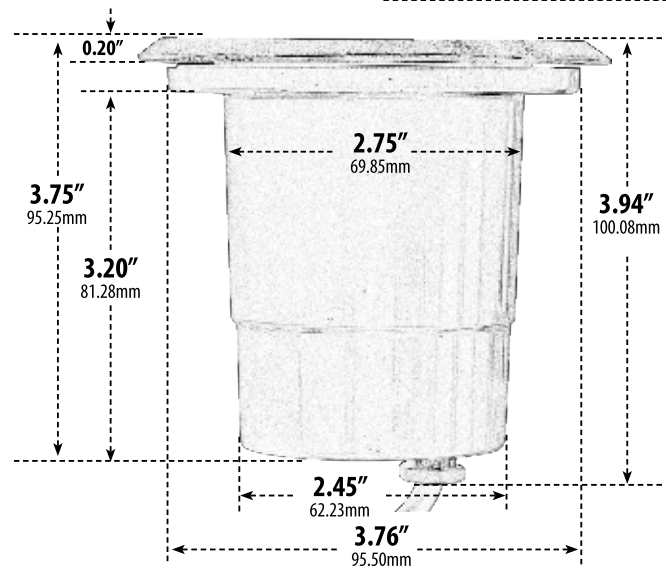
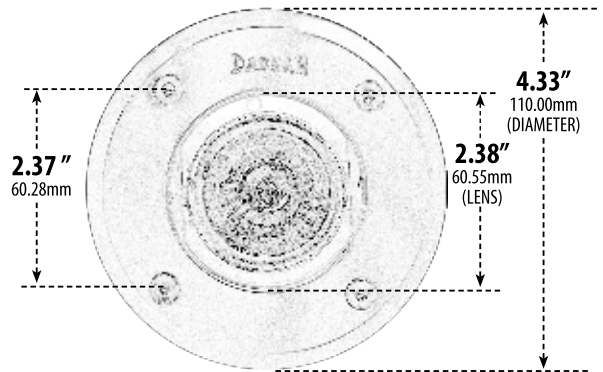

- ▶ **Material:** Fiberglass Body w/Stainless Steel Cover
- ▶ **Lens:** Clear, Heat Resistant, Tempered Glass
- ▶ **Lamp:** MR16 Bi-Pin Base (20W Maximum) Available in 27K or 65K

MODEL NUMBER	LAMP TYPE	ILLUMINANT TYPE	WATTS (W)	VOLTS (V)	LAMP(S) INCLUDED?
FG319	MR16	HALOGEN	20	12	YES
FG319-LED3	MR16-LED	LED	3	12	YES
FG319-LED5	MR16-LED	LED	5	12	YES
FG319-LED7	MR16-LED	LED	7	12	YES
FG319-LED4-RGBW	MR16-LED	LED	4	12	YES

Pre-wired with UL Listed Direct Burial Wire/Cable

- ▶ **Installation Type:** Rated for In-Ground Soil and Concrete Applications
- ▶ **Available Finish:** Stainless Steel
- ▶ **RGBW Lamp Requires/Remote:** P-RMT-MR16-LED-4W-MC (sold separately)
- ▶ **ETL Approved**

Overall Dimensions:
3.94"H x 4.31"W x 4.31"D

Weight: 1.00 lbs
Approximate Wire Length: 17"

Box Dimensions:
4.88"H x 4.38"W x 4.25"D

DABMAR
LIGHTING

DABMAR LIGHTING INCORPORATED

320 Graves Ave . Oxnard, CA 93030 . 805.604.9090 . f: 805.604.9050 . www.dabmar.com
4693 19th Street Ct E . Bradenton, FL 34203