

# D150

## PATH, WALKWAY, DRIVEWAY and ENTRANCE AREA BOLLARD

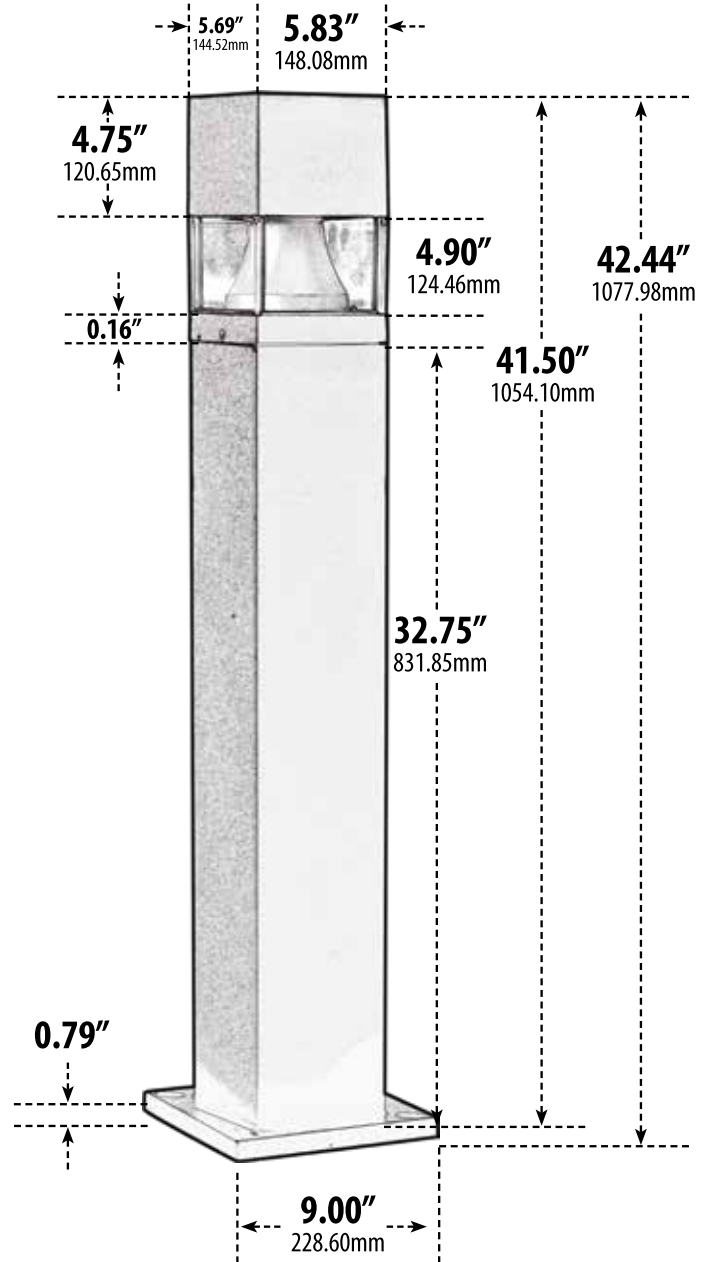

- ▶ **Material:** Fiberglass
- ▶ **Lens:** Clear, Heat Resistant, Polycarbonate Lens
- ▶ **Available Finish:** Black, Bronze
- ▶ **ETL Approved**

**DABMAR**  
LIGHTING

DABMAR LIGHTING INCORPORATED

320 Graves Ave . Oxnard, CA 93030 . 805.604.9090 . f: 805.604.9050 . www.dabmar.com

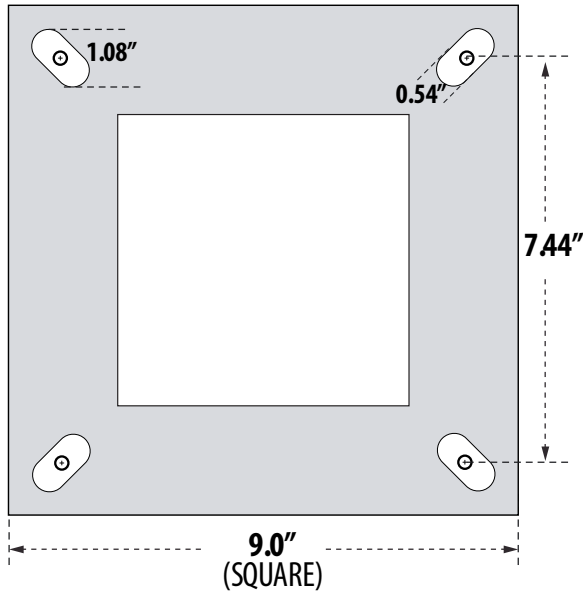

**BASE PATTERN**

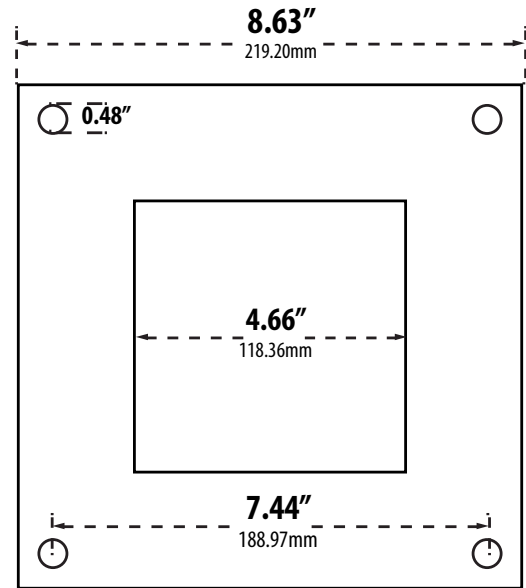

**TEMPLATE PATTERN**

**BOLT**



MODEL NUMBER	LAMP TYPE	ILLUMINANT TYPE	WATTS (W)	VOLTS (V)	LAMP(S) INCLUDED?
D150	A-Type	Incandescent	60	120	NO
D150-LED112	Tubular G24 2P	112 LEDs	20	120-277	YES
D152	HID	HPS	35	120	YES
D153	HID	HPS	50	120	YES
D153-MT	HID	HPS	50	MT	YES
D154	HID	HPS	70	120	YES
D154-MT	HID	HPS	70	MT	YES
D155-35	HID	MH	35	120	YES
D155	HID	MH	50	120	YES
D155-MT	HID	MH	50	MT	YES
D156	HID	MH	70	120	YES
D156-MT	HID	MH	70	MT	YES
D157	S13-GU24	Fluorescent	13	120	YES
D158	S23-GU24	Fluorescent	23	120	YES

Overall Dimensions:  
9.00"W x 42.44"H x 9.00"D

Maximum Height: 42.44"  
Width: 9.00"  
Maximum Depth: 9.00"

Weight: 11.60 lbs  
Box Dimensions: 9.75"W x 44.25"H x 9.75"D

**LED Available in 30K or 50K**

FIBERGLASS is warranted for a period of three (3) years from date of shipment

LED is warranted for a period of three (3) years or half the lifespan from date of shipment