

access

L I G H T I N G

INSTALLATION INSTRUCTIONS

IMPORTANT

Before assembling your ACCESS LIGHTING fixture, please make sure that you carefully read through these instruction sheets. Consider having your fixture installed by a qualified licensed electrician.

NOTE: The important safeguards and instructions that appear in this manual are not meant to cover all possible conditions and situations that may occur. It must be understood that common sense, caution and care, are factors that can't be built into any product. These factors must be supplied by the person(s) caring for and operating the fixture.

GENERAL INFORMATION

All electrical connections must be in accordance with all ordinances, Local and National Electrical Codes. These fixtures are intended for mounting to a standard 4" x 2 1/2" metal octagon outlet box. The box must be directly supported by the building structure and U.L. Recognized.

STEP BY STEP INSTRUCTIONS

Before starting your installation disconnect the Power by turning off the Circuit Breaker or by removing the fuse at the fuse box. Just turning the light off at the light switch is not sufficient to prevent electrical shock.

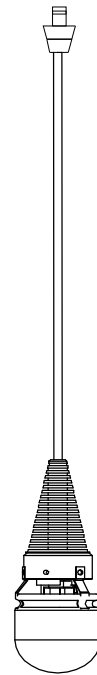

COLLECTION

ZETA

APPLICATION

Pendant Fixture

MODEL NO.

903UJ

WHAT WE PROVIDE

- Fixture Assembly
- 10ft Wire with lamp holder
- 1 x Glass Bulb cover
- 1x 35W GY6.35 bulb

WHAT YOU NEED

- Screwdriver
- Wire Cutters
- Wiring Supplies as Specified by Electrical Code
- 1x Glass Shade

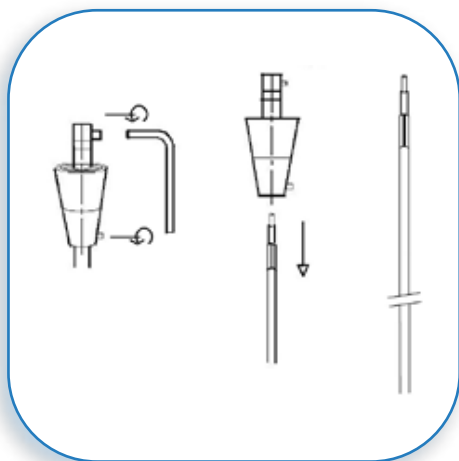

Determine the length of your fixture

1

Loosen the top and bottom allen screw with the supplied allen key.

Pull the wire out of the UNI-JACK connector.

Determine the length of your fixture.

Cut the wire to the desired length. Leaving an additional 1 1/2" for the necessary connections.

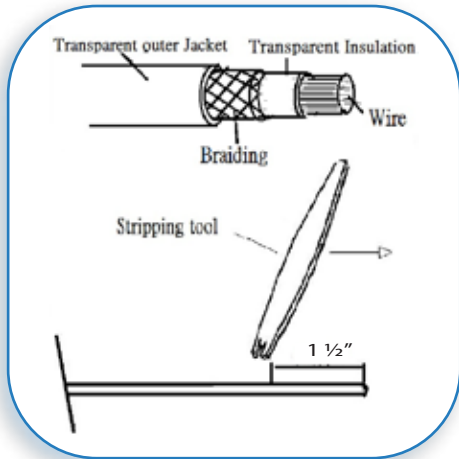

2

STRIP THE WIRE OUTER JACKET

Strip 1 1/2" of the outer jacket with the stripping tool or wire cutter.

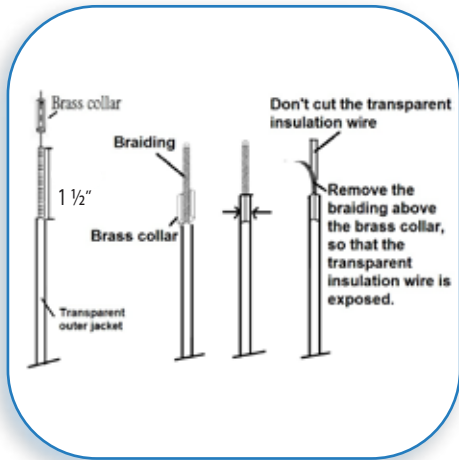

3

SLIDE THE BRASS COLLAR ON WIRE

Slide the brass collar over the braiding and clamp it gently. Remove the braiding above the brass collar, so that the transparent insulation wire is exposed. Don't cut the transparent insulation wire.

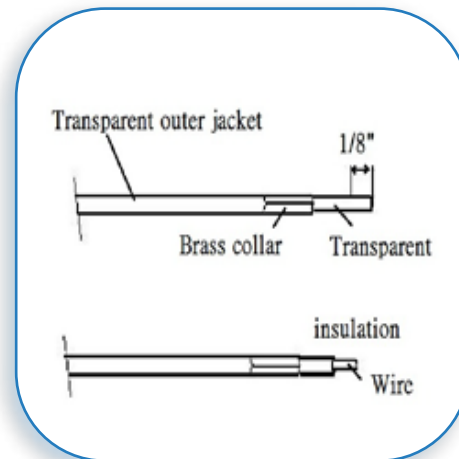

4

REMOVE THE WIRE INSULATION

Remove 1/8" of the transparent insulation to expose the inner wire. Solder the exposed wire to keep straight and neat.

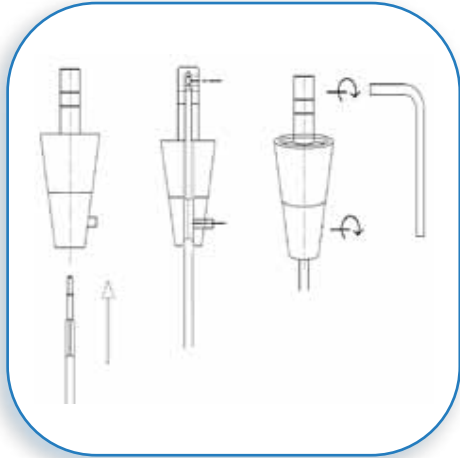

5

INSERT THE WIRE INTO THE UNI-JACK

Insert the wire into the UNI-JACK connector until it reaches the top set allen screw position. Make sure the brass collar aligns with the lower set allen screw. Tighten the top and the lower allen screw with the supplied allen key.

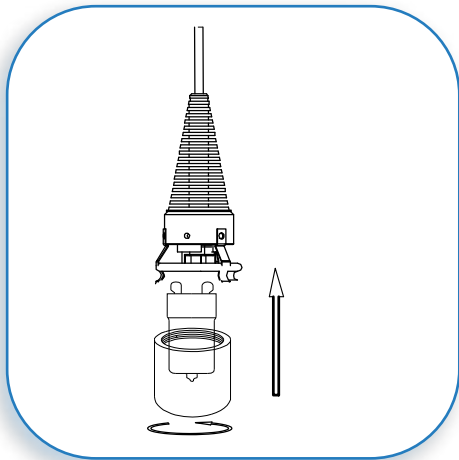

6

INSERT THE BULB AND SECURE BULB COVER

Insert the supplied bulb.
 MAXIMUM WATTAGE 35W TYPE JC Bulb (GY6.35Base).
 DO NOT EXCEED THE RECOMMENDED WATTAGE AS STATED ON THE WARNING LABEL AND INSTRUCTION SHEETS.
 Place the bulb cover up to the socket and screwing onto the threads on the socket.

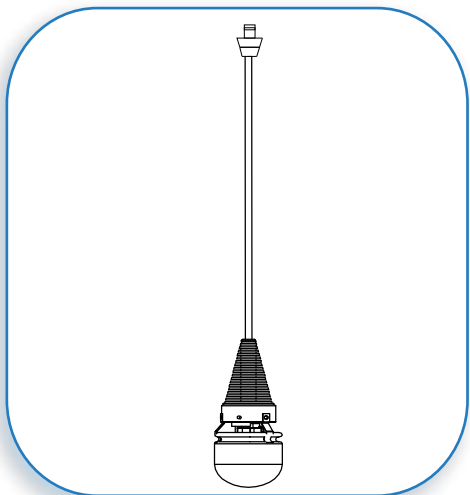

7

CONNECT THE UNI-JACK TO CANOPY PORT AND SECURE THE GLASS SHADE BEFORE RESTORE THE ELECTRICITY AND CHECK THE OPERATION OF YOUR NEW ACCESS LIGHTING FIXTURE

CAUTION Please ensure that the fitting is cool and switched off before replacing the bulb. DO NOT use bulbs that might exceed the maximum wattage, stated on caution label.